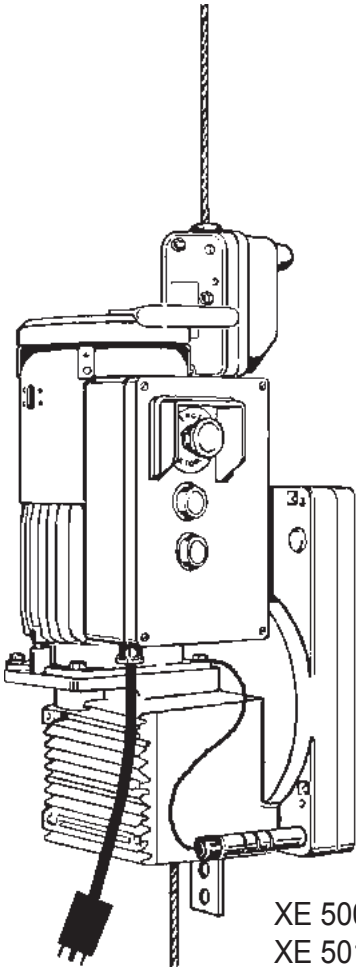


tirak™

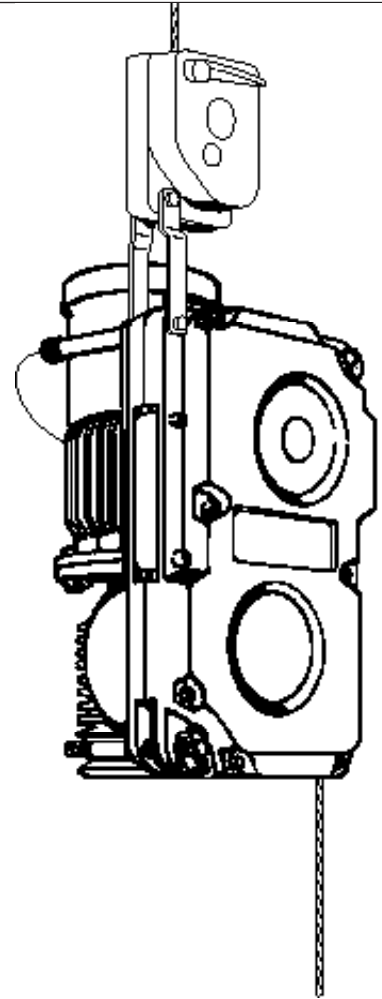
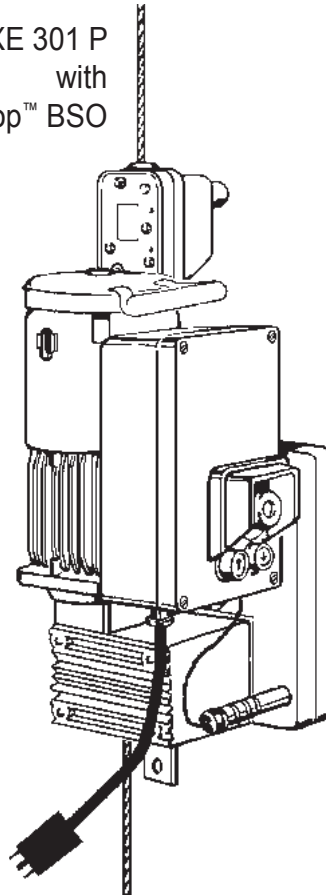
Scaffolding Hoist

Instruction Manual

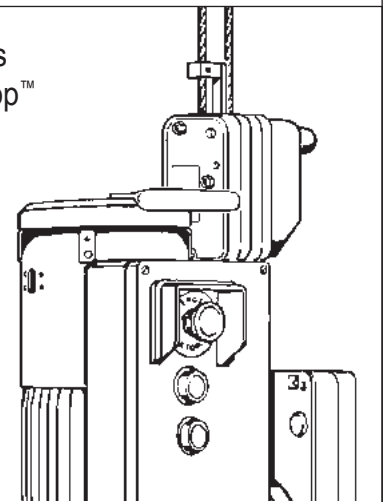
XE 301 P
with
blocstop™ BSO



XE 500 P
XE 501 P
XE 501 PA
XE 600 P
XE 700 P
XE 701 P
XE 720 P
XE 721 P
XE 1020 P
XE 1030 P
with blocstop™ BSO



tirak™ hoists
with blocstop™
BS/BSO on
2 wire rope
system



 **Tractel**®





GripHoist® Division
www.tractel.com

TABLE OF CONTENTS

INTRODUCTION	3	5. OPERATING INSTRUCTIONS	
1. GENERAL WARNING	4	5.1 General.....	14
2. DESCRIPTION		5.2 Normal Operation	15
2.1 Motor and Primary Brake	6	5.3 Emergency Descent	16
2.2 Gear Reducer	6	5.4 BSO Secondary Brake Action	16
2.3 Secondary Brake	6	6. TROUBLE SHOOTING	
2.4 Emergency Descent without power	6	6.1 Wire Rope Driving Mechanism	16
2.5 Wire Rope Driving Mechanism	6	6.2 Motor	17
2.6 Wire Rope	6	6.3 Primary Brake.....	17
2.7 Technical Data	7	6.4 BSO Secondary Brake	18
3. RIGGING INSTRUCTIONS		7. INSPECTIONS and MAINTENANCE	
3.1 General		7.1 Inspections	
3.1.1 Scope	8	7.1.1 Daily Inspections	18
3.1.2 Checks before rigging.....	8	7.1.2 Monthly Inspections	19
3.2 Power Supply and Hoist Control		7.1.3 1/2-Year Inspection	19
3.2.1 General.....	9	7.2 Maintenance	
3.2.2 Fuses / Circuit breakers	9	7.2.1 tirak™ Hoist	20
3.2.3 Power Cords and Grounding	9	7.2.2 Wire Ropes	20
3.2.4 Hoist Control	9	7.2.3 blocstop™ BSO Secondary Brake	20
3.3 Hoist Mounting			
3.3.1 tirak™ X-Series	10		
3.3.2 tirak™ T-Series	10		
4. WIRE ROPE		8. NAMEPLATES & LABELS	35
4.1 Wire Rope Specification	11	9. WARRANTY INFORMATION	37
4.2 Wire Rope Rigging Instructions	11	10. ADDITIONAL SOURCES AND TRAINING	37
4.3 Wire Rope Reeving	13	SCAFFOLD SAFE PRACTICE GUIDELINES	38
4.4 De-rigging.....	14		

ADDITIONAL INSTRUCTIONS for tirak™ with blocstop™ BS/BSO 21 to 34

Explanation of Symbols used in this manual

<u>Safety advice</u>			
Symbol	Code word	Meaning	Possible consequence of non-compliance
	WARNING	IMMEDIATE or possibly imminent danger:	Fatal or serious injuries!
	CAUTION	possibly dangerous situation:	Injuries to persons or damage to property
<u>Other advice</u>			
	NOTE	possibly dangerous situation:	Damage to equipment or its surroundings
	(none)	Instruction to execution/ documentation in writing (i.e. record keeping)	(none)

INTRODUCTION

Based on an original design, tirak™ wire rope scaffold hoists are specially manufactured for lifting personnel in a suspended platform system.



For that purpose they are UL classified.

tirak™ hoists are composed of the following main assemblies (Fig. 1):

- A Wire rope driving mechanism
- B Gearbox
- C Electric motor with primary brake and electric controls
- D blocstop™ BSO secondary brake,
- or
- E blocstop™ BS/BSO secondary brake

The main advantages of tirak™ hoists are:

- Powerful, fast, and lightweight.
- Simple, rugged, and reliable.
- Unlimited lifting height.
- Constant speed on any height.
- Gentle for its wire rope.
- Emergency descent with a mechanical emergency descent device.

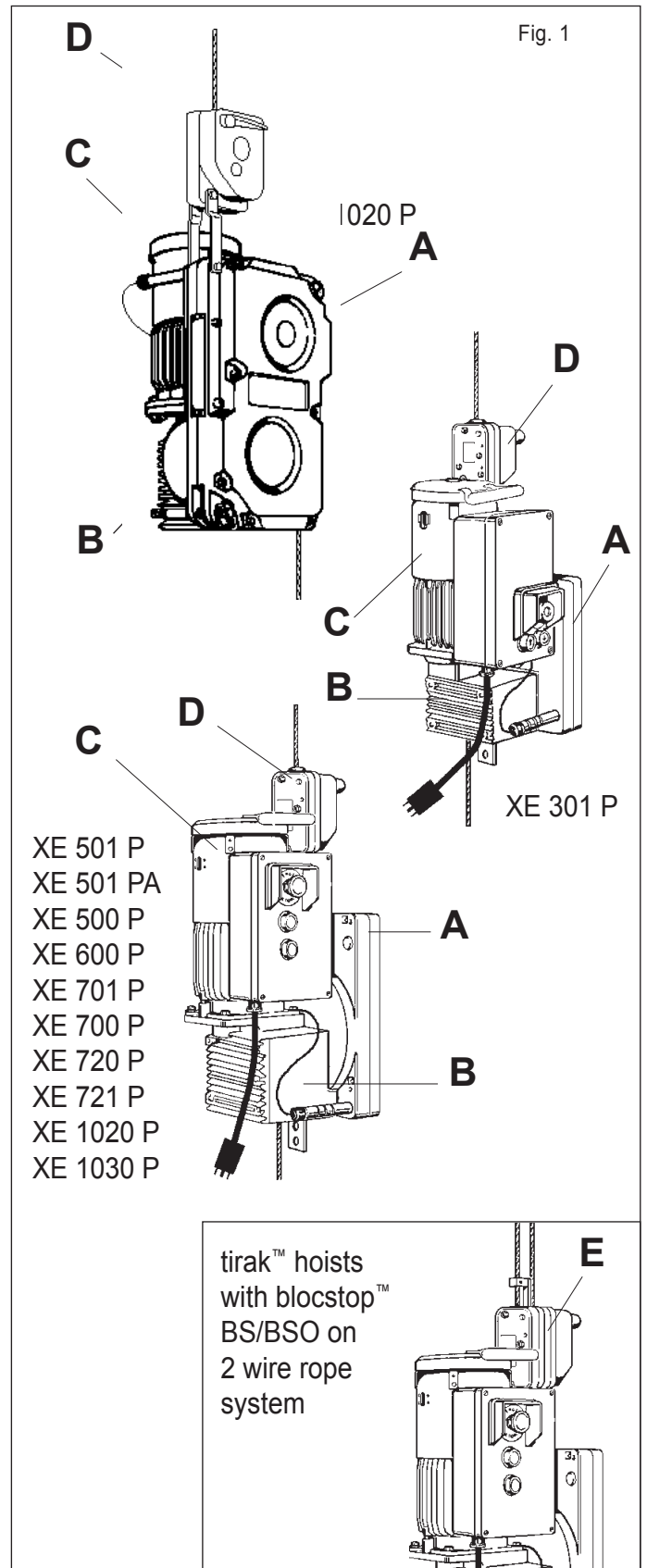
The **secondary brake** (D) or (E), marked blocstop™ BSO or BS/BSO **MUST ALWAYS BE ATTACHED AND USED.**

The original design requires, for safety and efficiency, that it be used with a **special tirak™ wire rope** specified by the manufacturer¹⁾.

tirak™ hoists are intended to be used for work going up and down a vertical hanging wire rope.

tirak™ hoists are designed to be rigged to a **compatible** platform, workcage or bosun's chair.

This manual gives the required information for rigging, operating and maintaining the tirak™ hoists. Responsibility for the complete suspended platform system lies upon the rigger of that system.



Specification of “manufacturer” and “supplier” referred to in this manual:

“Manufacturer” definition:

TRACTEL Greifzug GmbH
Postfach 20 04 40
51434 Bergisch Gladbach
GERMANY

“Supplier” definition regarding contact advice in this manual:

TRACTEL Ltd. Griphoist® Division
11020, rue Mirabeau
Anjou, QUEBEC, HIJ 2S3, Canada
Tél.: (514) 493-3332
Fax: (514) 493-3342

TRACTEL Inc. Griphoist® Division
110 Shawmut Road, Suite 2
CANTON, MA. 02021
Tel.: (800) 421-0246 • Fax: (781) 828-3642
Email: griphoist@worldnet.att.net



1. GENERAL WARNING



READ THIS GENERAL WARNING FIRST

IN SUSPENDED SCAFFOLD OPERATIONS, SAFETY IS A MATTER OF LIFE OR DEATH FOR RIGGERS, OPERATORS AND BY-STANDERS. THIS WARNING IS YOUR SHARE OF DUTIES FOR ACHIEVING SAFETY.

YOUR DUTY TO UNDERSTAND AND COMPLY

1. It is the rigger's and the operator's responsibility, and their employer's responsibility, if they operate under an employer's control, to strictly conform to the following warnings.
2. It is imperative for safety and efficiency of the operations that this manual be read and **fully understood** by the rigger and the operator before rigging or operating the tirak™. **ALL instructions** contained herein must be carefully and strictly **followed**, including applicable S.I.A. guidelines for safe practice (see pages 38 and 39).
3. Should you hand over a tirak™, under whatever conditions, to any party operating out of your control, you must join a clean copy of this manual and draw other party's attention that strictly following all the instructions therein is a matter of life or death.
4. Before rigging and operating this tirak™ hoist, the rigger and the operator must become aware of all the requirements of federal, state, provincial and local safety regulations not only applicable to the tirak™ hoist but also to the entire suspended scaffold system and any component of it.
5. Never use the tirak™ hoist for any job other than lifting personnel on suspended scaffold according to the instructions of this manual
6. Never load the tirak™ hoist above its rated load.

YOUR DUTY TO INSPECT AND MAINTAIN

7. Keep this manual available at all times for easy reference whenever required. Extra copies are available from the supplier.
8. Carefully take notice of all the labels affixed to the tirak™. Never rig or operate the hoist if any label, normally fixed on the hoist is obscured or missing (see page 35 and 36). The supplier will supply extra labels on customer's request.
9. Every time the hoist is to be rigged or used, check that the hoist, wire rope and other components of the suspended scaffold system are complete and in good working condition, prior to proceeding.
10. A careful and regular inspection of the tirak™ hoist, its wire rope and other components of the installation is part of the safety requirements. If you have any questions, call the supplier.
11. After each de-rigging and before re-rigging, the tirak™ must be inspected by a competent person familiar with the tirak™ hoist and professionally trained for the purpose.

YOUR DUTY TO TRAIN AND CONTROL PEOPLE

12. An operator must not be assigned to a suspended job or to rigging for a suspended job, or to de-rigging after the job, if that person is not:
 - a) mentally and physically fit for the purpose, specially at heights,
 - b) competent for the job to be performed,
 - c) familiar with all applicable safety rules and requirements,
 - d) familiar with the scaffold equipment as rigged,
 - e) provisionally trained for working under the above requirements.
13. Never disassemble the tirak™ by yourself or by your staff. People's life may be at risk.
14. Except for the operations described in this manual, the maintenance of the tirak™ hoists, as well as disassembly and repair, must be exclusively done by qualified repairers authorized in writing by the supplier. tirak™ spare parts in accordance with the serial number of each machine must be exclusively utilized. No substitutions are allowed.
14. Never let the tirak™ hoist and other equipment of a suspended scaffold system be managed or operated by a person other than authorized and assigned to the job. Keep the equipment, either rigged or unrigged, out of reach of unauthorized persons, while out of operation.

15. Training operators and riggers includes setting up rescue procedure should a scaffold be brought to a standstill during a job. Such procedure must be set up by a competent person of the user, or of its technical consultant, according to the working conditions, prior to putting the equipment into operation.
16. Every suspended job must be placed under the control of a person having the required competence and the authority for checking that all the instructions prescribed by this manual be regularly and efficiently carried out.

YOUR DUTY OF SAFETY BEYOND THE TIRAK

As being only one piece of the scaffold system, the tirak™ hoist can contribute to the required **safety only, if ...**:

17. ... it is fitted on compatible scaffold equipment, including the wire rope used in the tirak™ hoist.
18. ... other components meet the requirements of the applicable safety regulations and are of the proper quality, and assembled to form a safe suspended scaffold system.
19. ... every upper support of the scaffold is stable, sufficiently strong and properly tied back to the structure, according to the load either static or dynamic.
20. ... supporting structure and tie-back provide the requested resistance to every load to be applied, either static or dynamic, during rigging or operating the scaffold equipment;
21. ... all the requirements in strength and resistance are obtained with the necessary safety factor (see regulations and professional standards);
22. ... all the calculations, design and subsequent work necessary to the above requirements have been made by a competent person on the basis of proper technical information regarding the site.

YOUR DUTY TO AVOID TAKING CHANCES

23. The blocstop™ BSO or BS/BSO secondary brake located at the upper part of the unit is an **integral piece of the tirak™ hoist**. It is strictly forbidden to detach it from the main body of the hoist for whatever reason. Doing so would be a misuse creating an extreme hazard and placing operators and by-standers in danger of death resulting from the possible fall of the suspended equipment: scaffold, workcage, bosun's chair or any other items or components.
24. Once the suspended scaffold, work-cage or bosun's chair has been lifted off its initial support (ground or any other level), it is imperative not to release, remove, alter or obstruct any part of the equipment under load.
25. NEVER allow any condition which would result in a suspension wire rope becoming SLACK during the operation, unless ...:
 - a) ... the suspended scaffold, work-cage or bosun's chair is supported on a safe surface giving a safe access to the operator in compliance with safety regulations, or unless ...
 - b) ... another suspension wire rope has been safely rigged to the suspended scaffold, workcage or bosun's chair.
26. Never operate the tirak™ hoist and its accessories, especially electric ones, in a potentially explosive atmosphere.
27. For any job to be performed on the suspended equipment, consider and control the specific risks related to the nature of the job.
28. Should you decide that the tirak™ hoist is no longer to be used, take precautions in disposing of it so that it cannot be used any more.

AN ULTIMATE RECOMMENDATION

Never neglect means to improve safety. Due to the risks inherent in the use of suspended scaffold systems, the supplier strongly recommends that every installation be equipped with secondary wire rope(s) fitted with a separate fall arrest system. Details about tirak™ with blocstop™ BS/BSO secondary brake on 2 wire rope systems at pages 21 to 34.

This manual is neither a regulations compliance manual nor a general training guide on suspended scaffold operations. You must refer to proper instructions delivered by manufacturers of the other pieces of equipment included in your suspended scaffold installation. Whenever calculations and specific rigging and handling are involved, the operator should be professionally trained to that end and secure relevant information prior to commencing such work.

2. DESCRIPTION

2.1 Motor and Primary Brake

tirak™ hoists are driven by a single phase or a three phase motor, totally enclosed fan cooled (TEFC) type with an electromagnetic brake. Pneumatic tirak™ hoists are available also.

2.2 Gear Reducer

The gear reducer consists of a worm gear drive in connection with a spur gear, oil bath lubricated in a sealed aluminum casing.

2.3 Secondary Brakes

The blocstop™ BSO overspeed locking device

(D) – hereafter called BSO secondary brake – stops the descent immediately in case of accelerating overspeed.

The blocstop™ BS/BSO overspeed and slack wire rope locking device (E) – here-after called BS/BSO secondary brake – additionally provides protection against slack wire rope or primary wire rope failure, when using secondary wire ropes.

SECONDARY BRAKES MUST ALWAYS BE ATTACHED AND USED.

2.4 Emergency Descent without power

tirak™ hoists are equipped with a mechanical centrifugal braking system, permitting a descent at moderate speed in case of emergency. No handcranking is needed.

2.5 Wire Rope Driving Mechanism

The wire rope enters the hoist from the top,

is led through by the patented driving system, and exits opposite its entry. As the wire rope is not stored inside the hoist, its length (i. e. the possible rope travel) is unlimited on principle.

The driving system is independent of the load applied to the wire rope. The whole mechanism is housed in an aluminum casing.

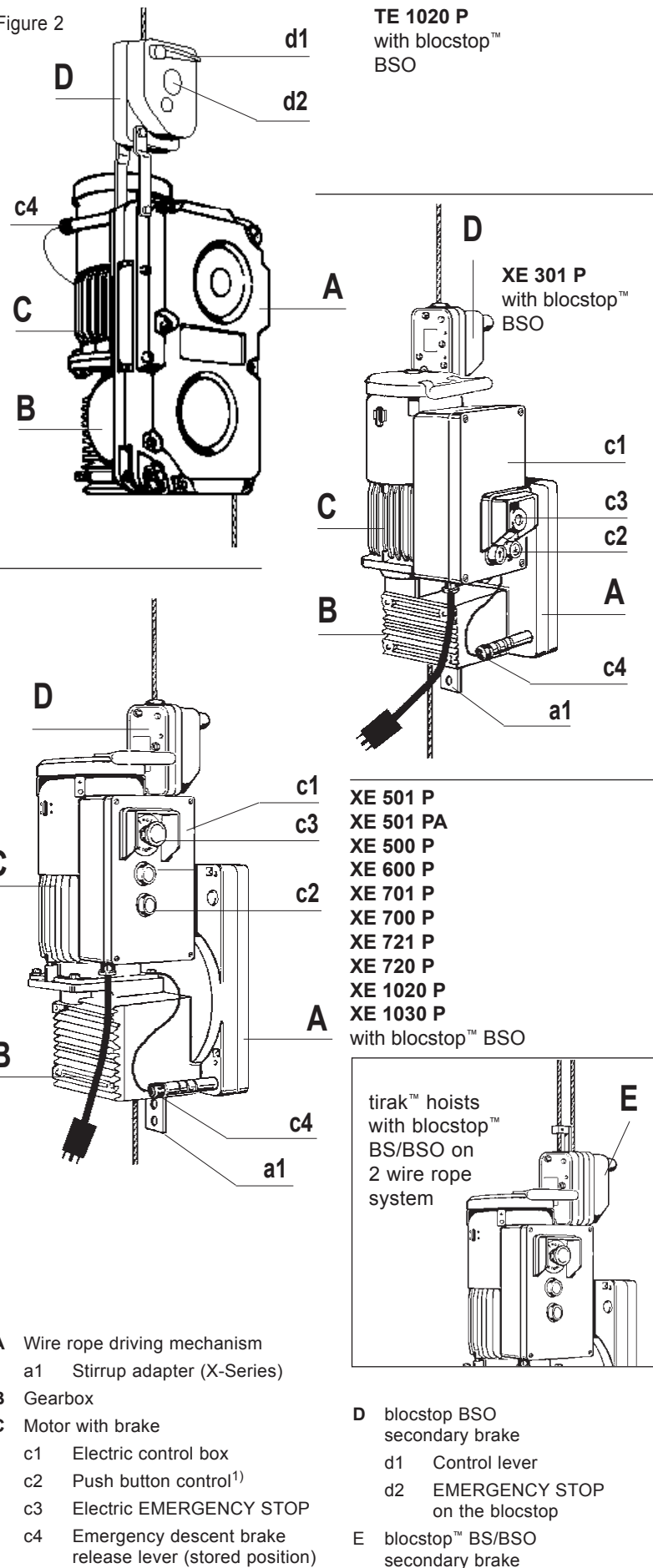
2.6 Wire Rope

tirak™ hoists use a **Special tirak™ Wire Rope** (see chapter 4). Unless specifically specified in writing by the manufacturer, only this special tirak™ Wire Rope may be used.

NOTE: The manufacturer declines all responsibility for machines used with a wire rope other than specified by them in writing.

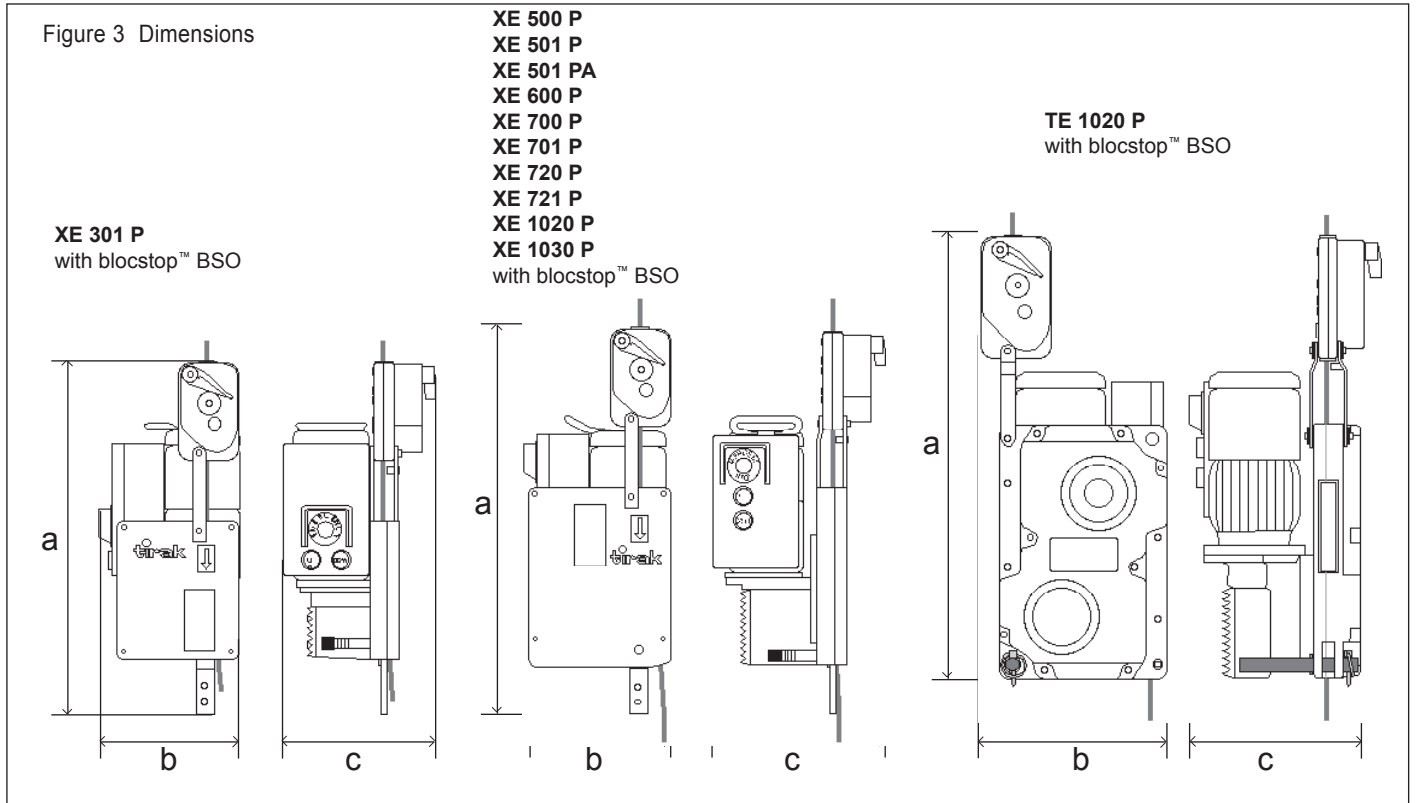


Figure 2



1) For all hoists pendant control and pushbutton control are available on request.

2.7 Technical Data



Hoist Model		XE 301 P	XE 501 P	XE 501 PA	XE 500 P	XE 600 P	XE 701 P	XE 700 P	XE 721 P	XE 720 P	XE 1020 P	TE 1020 P	XE 1030 P	
with blocstop model		BSO 500												
		BSO 1020												
Rated load	lbs	700	1000	1000	1000	1200	1500	1500	1500	1500	2200	2000	2200	
	kg	315	450	450	450	544	680	680	680	680	1000	1000	1000	
Lifting speed	ft/min	33	35	35	35	35	35	35	35	35	35	35	35	
	m/min	10	11	11	11	11	11	11	11	11	11	11	11	
Weight (with BSO)	lbs	82	123	121	106	112	123	112	126	115	120	178	120	
	kg	37	56	55	48	51	56	51	57	52	54	81	54	
Dimensions over all														
a	in.	28.9	31.8	31.8	31.8	31.8	31.8	31.8	31.8	33.3	33.3	33.3	34.6	33.3
	mm	735	808	808	808	808	808	808	808	845	845	845	879	845
b	in.	11.2	12.9	12.5	12.1	12.5	13.2	12.5	13.2	12.5	12.5	12.5	14.8	12.5
	mm	286	328	318	308	318	336	318	336	318	318	318	375	318
c	in.	12.5	15.8	14.1	14.1	14.1	14.9	14.1	14.9	14.1	14.1	14.6	14.1	
	mm	314	402	357	357	357	379	357	379	357	357	371	357	
Motor specifications														
3-phase 220V/60 cycles	kW	–	–	–	1.1	1.5	–	1.5	–	1.5	2.4	2.2	2.4	
	A	–	–	–	4.5	6.1	–	6.1	–	6.1	9.6	9.5	9.6	
single phase: 110 (or 220V)/ 60 cycles	kW	0.55	1.1	–	–	–	–	–	–	–	–	–	–	
	A	10.0	19.0/(8.5)	–	–	–	–	–	–	–	–	–	–	
220 V / 60 cycles	kW	0.55	–	1.1	–	–	1.5	–	1.5	–	–	–	–	
	A	4.8	–	8.5	–	–	12.0	–	12.0	–	–	–	–	
wire rope dia- meter	in.	5/16							3/8				13/32	
	mm	8.4							9.5				10.2	

CAUTION:



Correct wire rope diameter is very important for the tirak™ function!

An oversized wire rope may cause a wire rope jam inside the hoist and/or the BSO or BS/BSO secondary brake to malfunction.

wire rope classification/ construction	5 x 19, 4 x 26, or 5 x 26, with fiber core, or 6 x 19 (min. 17 wires per strand), galvanized or black, lubricated,			
nominal diameter	in./mm	5/16 in. / 8.4 mm	3/8 in. / 9.5 mm	13/32 in. / 10.2 mm
maximum allowed diameter tolerances	in. mm	0.319 to 0.331 8.1 to 8.4	0.362 to 0.374 9.2 to 9.5	0.390 to 0.400 9.9 to 10.2
minimun actual breaking strenght	lbs kN	10,000 44.5	15,000 66.8	18,660 83.0

3. RIGGING INSTRUCTIONS

3.1 GENERAL

3.1.1 Scope

Instructions and advice in this manual exclusively refer to the following items (see Fig. 4):

- **TIRAK scaffold hoist with blocstop™ BSO secondary brake or BS/BSO¹⁾ secondary brake;**
- **Special TIRAK wire rope;**
- **Power supply cord.**

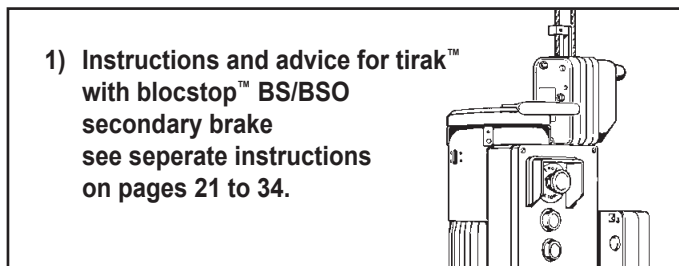
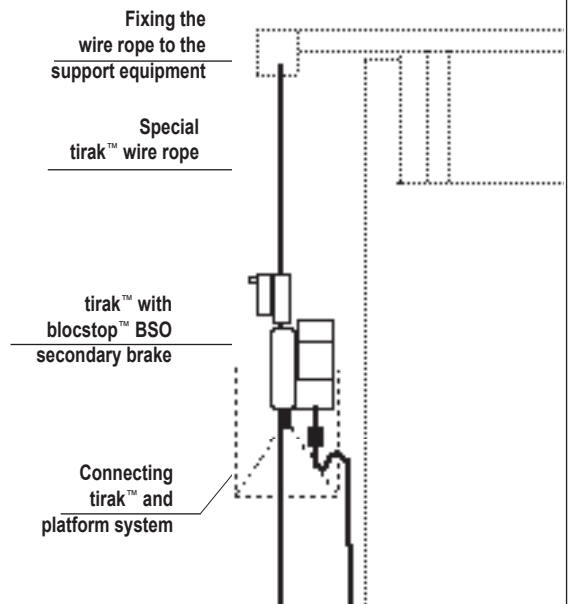


Fig. 4 Relevant Items (principle sketch)



3.1.2 Checks before rigging

It is a qualified person's responsibility to check the whole installation to meet all safety requirements of:

- OSHA regulations and federal, state, provincial or local safety regulations,
- the proper instructions delivered by the manufacturers of the other pieces of equipment included in your suspended scaffold installation.

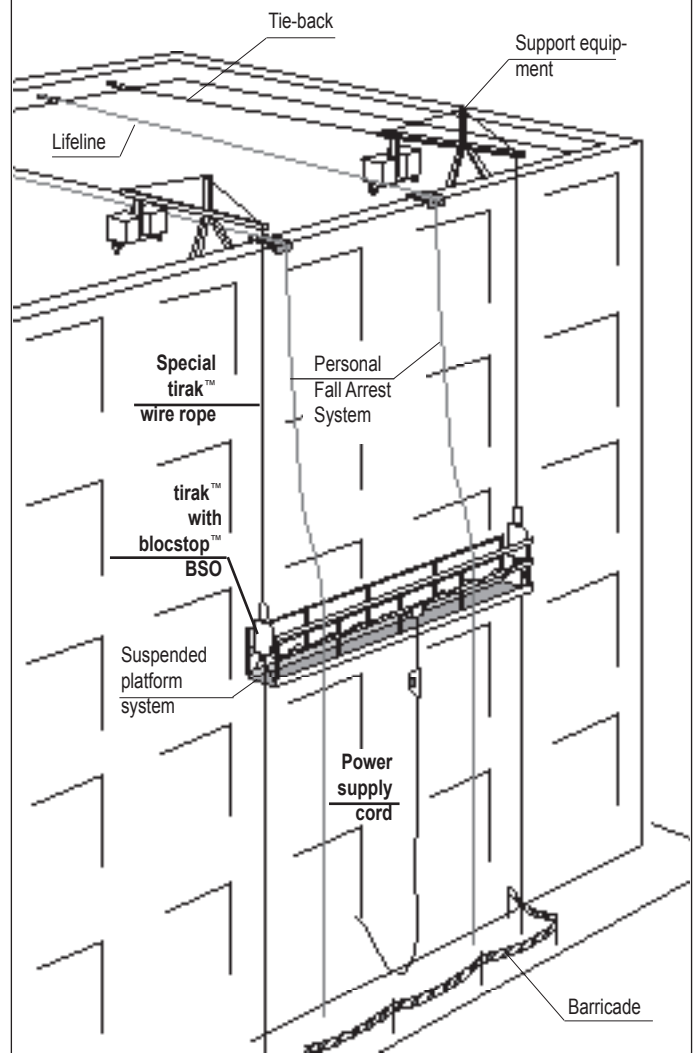
Some pieces are:

- Support equipment including tie-back;
- platform system, work-cage, or bosun's chair;
- safety equipments (personal fall arrest system);
- barricade below the drop of the platform/work-cage/bosun's chair.

NOTE: This information is **NOT to be considered** as a complete checklist for your specific installation. It is only a sample list of some general components, which make part of a typical suspended scaffold installation (Fig. 5).



Fig. 5 Typical suspended scaffold installation



3.2 Power Supply and Hoist Control

3.2.1 General

- (1) Check if voltage indicated on the hoist nameplate corresponds to the power supply rating.
- (2) **Single phase motors** are factory connected for either 220 VAC or 110 VAC.

On dual voltage machines change plug and wiring according to drawing inside control box.

Three phase machines are factory connected for 220 VAC, 3 Ø.

- (3) It is important to note that SINGLE-PHASE motors are more sensitive to overloading and voltage drop than three phase motors.

Therefore never exceed maximum rated load, and see to it that the 110/220 VAC power supply is always available.

In case of difficulties have an electrician or qualified person read voltage at motor terminal during lifting operation. Especially for high lifting operations, which require long cords, it is essential to use power cords of sufficient size (see par. 3.2.3) to avoid excessive voltage drop.

- (4) **WARNING: NEVER OPERATE THE HOIST OR ANY OTHER ELECTRIC EQUIPMENT IN A POTENTIALLY EXPLOSIVE ATMOSPHERE: around distilleries, refineries, chemical plants, ship or silo interiors.**



Always obtain official approval before commencing operations at these or similar locations.

3.2.2 Fuses / Circuit breakers

If connected to a circuit protected by a fuse, use **Time-Delay-Fuse**.

Check if specification of fuses, which protect electrical equipment, corresponds to the amperage indicated on the machine nameplate. The recommended service requirements **per hoist** are:

Single phase	Three phase	amps.
110 V	220 V	30
220 V	–	20

3.2.3 Power Cords and Grounding

- (1) To prevent voltage drop exceeding the allowable 10% we recommend to use at least #10, STO type power cords, 600 VAC rating.

To minimize voltage drop due to power cord length on high lifts, select an outlet at the halfway point to reduce the total power cord length on the job.

- (2) In some cases, a booster transformer will be needed to compensate for power cord losses or low-source voltage. If a booster transformer is needed, call supplier.

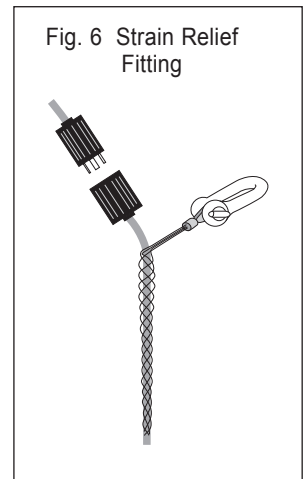
- (3) **CAUTION: DO NOT OPERATE THE MOTOR FOR ANY REASONS, IF THE MEASURED RUN VOLTAGE IS LESS THAN THE MOTOR NAMEPLATE RATING!**



- (4) Always secure the power cord to the platform with a strain relief fitting and shackle (Fig. 7), so the cord weight will be off the connector.

- (5) When finished for the day, make certain the power cord is disconnected at the hoist pigtail as well as at the main outlet.

- (6) Be sure to **ground all electric equipment**. Do not use wire rope as a ground!



3.2.4 Hoist Control

Control (Fig. 7) is by

- **push-buttons**, which automatically return into STOP-position, when not activated, and an
- **EMERGENCY STOP button**.

DO NOT fix push-buttons in run position.

Other possible control: pendant control (available on request)

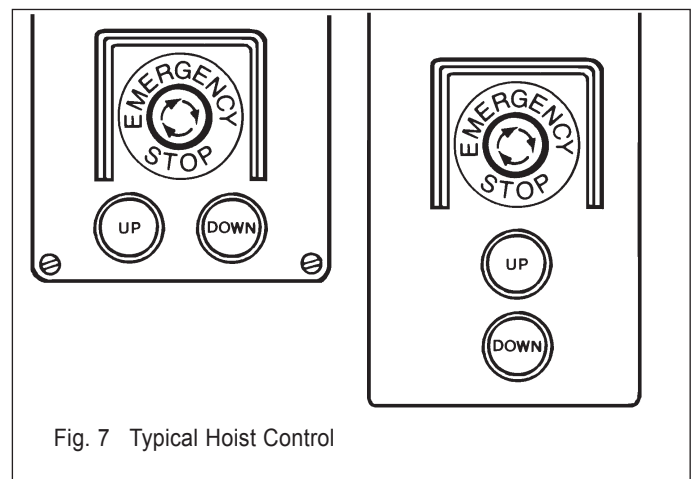


Fig. 7 Typical Hoist Control

3.3 Hoist Mounting

3.3.1 tirak™ X-series

Bolt the hoist to platform stirrup using **stirrup adapter**, which also holds the hoist in its upright position (see Figs. 8 and 10).

Use two 1/2 inch diameter grade 5 or better bolts with locking nuts.



WARNING:
HOIST CONNECTION
BOLTS MUST NOT
BEAR ON THREADS.

3.3.2 tirak™ T-series

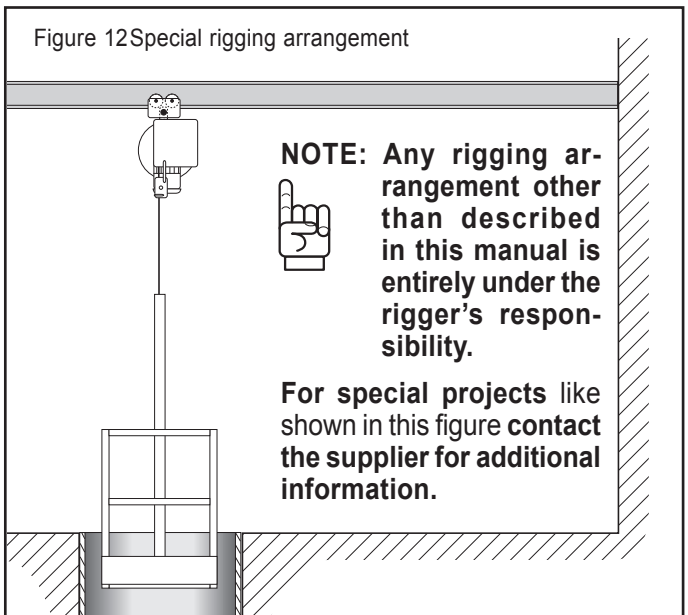
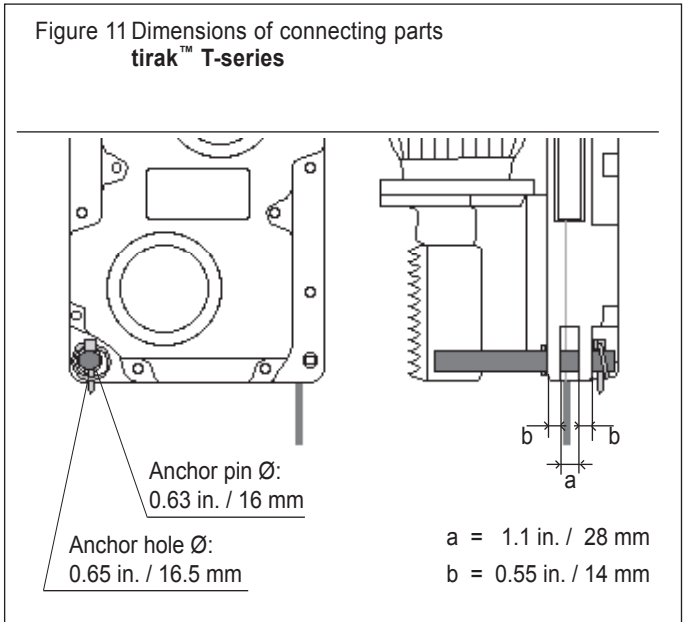
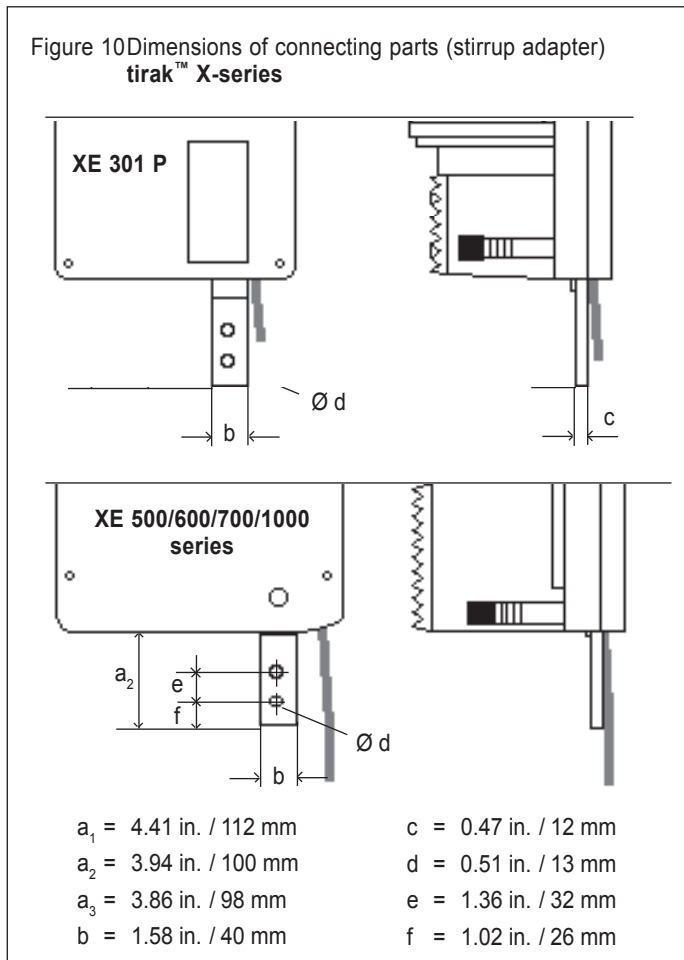
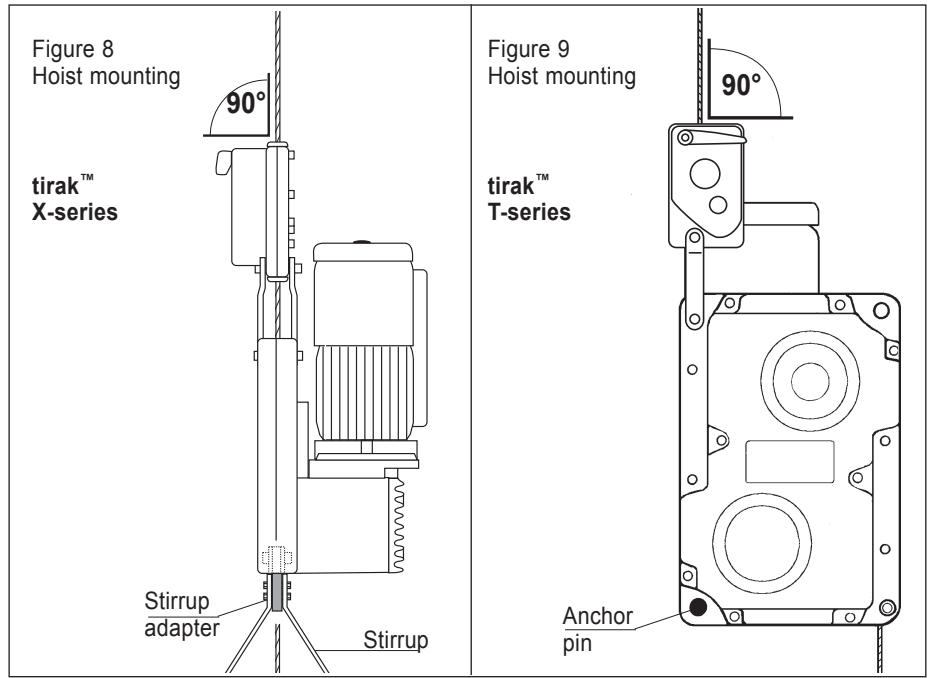
Fix the hoist using its **anchor pin** (see Fig. 9 and 11). Make sure that the hoist is held in its upright position by means of an appropriate support. The anchoring device must attach to the pin between the 2 cast ears "b" of Fig. 11.



WARNING:
THE HOIST MUST BE MOUNTED SUCH
THAT THE WIRE ROPE PERPENDICU-
LARLY ENTERS THE HOIST.



(Figs. 8 and 9)



4. Wire Rope

4.1 Wire rope specification

Use only wire ropes specified by the manufacturer:

- (1) **Classification/Construction:**
5x19, 4x26, or 5x26, with fiber core, or 6x19, (min. 17 wires/strand), galvanized or black, lubricated, preformed IPS or XIPS.

- (2) **Diameter:**

wire rope diameter ¹⁾	min. actual breaking strength	for tirak™ hoists with rated load up to
5/16 in. 8.4 mm	10,000 lbs 44.5 kN	1,500 lbs 680 kg
3/8 in. 9.5 mm	15,000 lbs 66.8 kN	2,200 lbs 1,000 kg
13/32 in. 10.2 mm	18,660 lbs 83.0 kN	1,850 lbs 840 kg

- 1) **Maximum allowed tolerances of NEW wire rope diameter:**

5/16 in. (8.4 mm) = **0.319** to **0.331** in. (8.1 to 8.4 mm)
 3/8 in. (9.5 mm) = **0.362** to **0.374** in. (9.2 to 9.5 mm)
 13/32 in. (10.2 mm) = **0.390** to **0.400** in. (9.9 to 10.2 mm)

CAUTION:



Correct wire rope diameter is very important for the tirak™ function!

An oversized wire rope may cause a wire rope jam inside the hoist and/or the BSO or BS/BSO secondary brake to malfunction.

NOTE: How to measure wire rope diameter:



The correct diameter of the wire rope is the largest cross-sectional measurement across the strands (and not the valleys).

The measurement should be made carefully with calipers as shown in Fig. 13.

4.2 Wire rope rigging instructions



WARNING:

Be sure to use a wire rope with the diameter marked on the tirak™ nameplate.

- (1) **RIG FROM TOP.**

You should have enough wire rope to reach to the ground or other safe level with about five feet (1.5 m) extra for ensuring safety.

CAUTION:



Always unreel and reel the wire rope in a straight line (Fig. 14) to prevent kinks, which make it unusable for the hoist.

Figure 13 Checking Wire Rope Diameter "d"

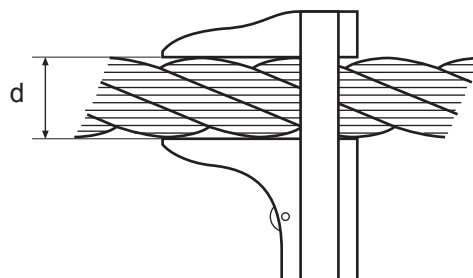


Figure 14 Wire Rope Handling



4.2 Wire rope rigging instructions (continued)

(2) If the wire rope is not equipped with a swaged fitting as shown in Fig. 15, proceed as follows:

- Install heavy duty thimble with a minimum of three (3) J-Type (Fist Grip) Clamps (Fig. 16).
- Apply first clamp approximately 7" (18 cm) from thimble. Tighten nuts moderately.
- Attach second clamp as close to thimble as possible. Leave nuts loose.
- Attach the third clamp half-way between first and second clamp, leaving the nuts loose. Take up wire rope slack.
- Tighten nuts evenly on all clamps (approx. 30 ft-lbs. torque) as specified by the clamp manufacturer.

WARNINGS:



- a) **Retighten after the wire rope is loaded for the first time**
- b) **Inspect fastening periodically.**

In use, wire ropes will stretch and reduce in diameter.

Retighten all "Fist Grip" nuts periodically.

(3) Anchor the wire rope end to a rigging device, which complies with all relevant safety requirements.

Be sure to use compatible connecting devices, e. g. a 1/2 in. anchor shackle or similar with adequate strength and safety factor. Secure it.

(4) Insure that the anchor points of the wire rope are directly above the position of the hoists (Fig. 17).

WARNING:

Improper spacing is dangerous and could cause failure of the support system.



- (5) Check that wire rope tip is welded round (Fig. 18). IF NOT:

- a) Prepare ends by **brazing or welding** – **make sure all end wires are captured.**
- b) Grind end to approximately 1/4" diameter. **DO NOT** grind end flat or to a cone shape. End **must be rounded** (Fig. 18).
- c) The last 4 in. (10 cm) of wire rope must be straight for proper reeving.

Figure 15

Wire Rope Termination by Swaged Fitting

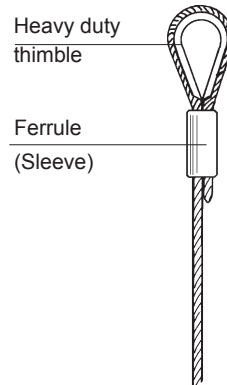


Figure 16

Wire Rope Termination by Fist Grip Clamps

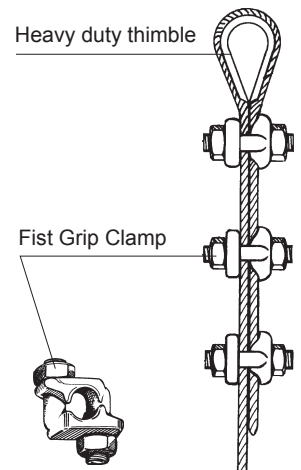


Figure 17 Suspension Distance

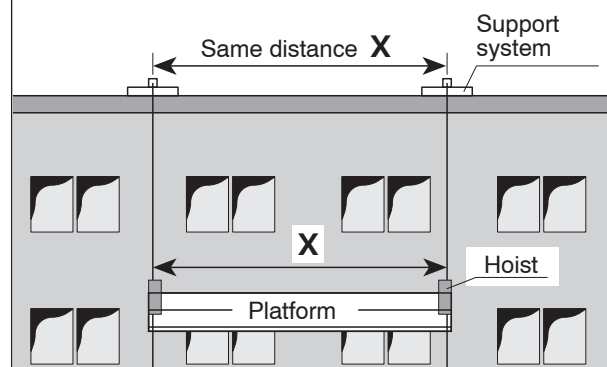
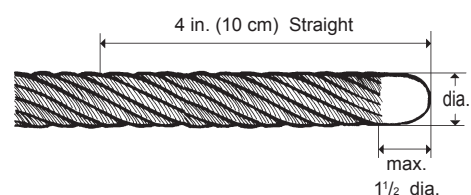


Figure 18 Wire Rope Tip



4.3 Wire rope reeving

(1) Open the BSO secondary brake by pushing down the control lever (d1) until it locks (Fig. 19).

(2) Push the rope through the BSO secondary brake at (A) into the hoist rope inlet (B).

Push it inside, and press UP-button, until the wire rope reeves itself automatically and exits at (C) on the other side (Fig. 20).

CAUTION:



Check that wire rope exit (C) is not blocked in any manner.

Never load the wire rope exiting from (C).

Figure 19 Opening of BSO Secondary Brake

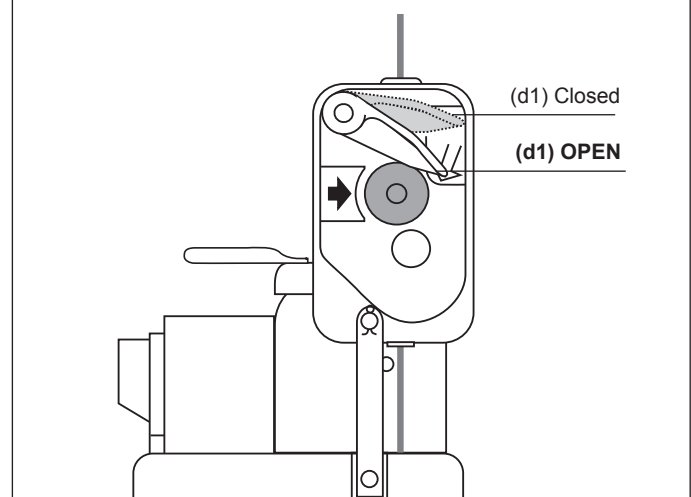
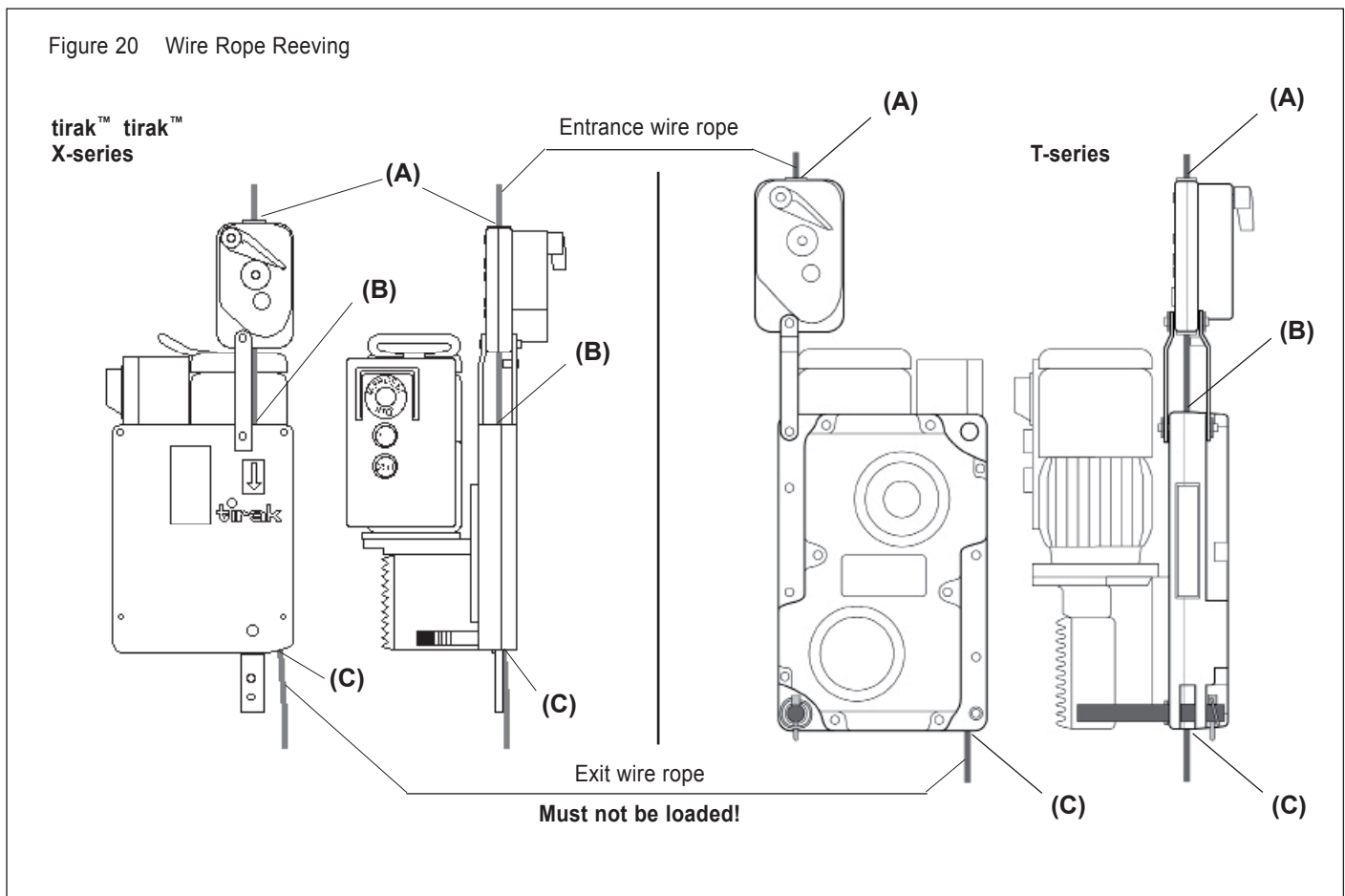


Figure 20 Wire Rope Reeving



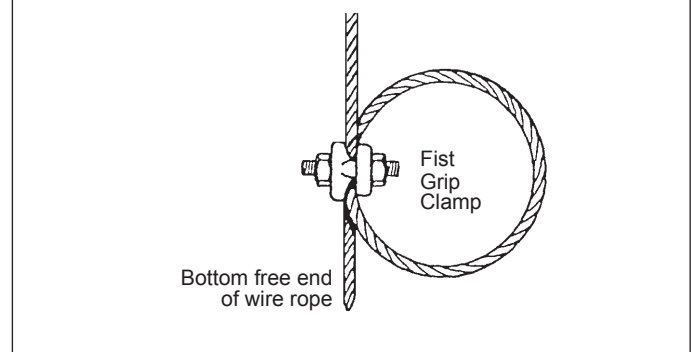
(3) After reeving through the hoist, be sure to loop and clamp the free end of the wire rope, to prevent the rope from inadvertently unreeving through the hoist.

Always tie this loop, using a fist grip clamp, when the platform is at ground level or other safe surface (Fig. 21).



WARNING:
AT EVERY SET-UP OR RERIGGING check the wire rope length to ensure that it reaches the ground or other safe level with about five feet (1.5 m) extra for safety.

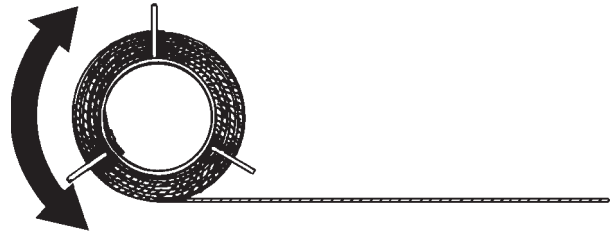
Figure 21 Loop at Free Wire Rope End



4.4 De-Rigging

- (1) Before de-rigging each tirak™ hoist must be unloaded by bringing down the platform to a safe and stable support.
- (2) Remove the loop at the free wire rope end.
- (3) Press DOWN button to let the wire rope run out.
- (4) With gloved hands slowly pull the wire rope through BSO secondary brake.
- (5) Clean the wire rope, reel it (Fig. 22), and store it in a clean and dry place.

Figure 22 Wire Rope Handling



5. Operating Instructions

5.1 GENERAL

- (1) BE FAMILIAR with the equipment and its proper care.

DO NOT operate hoist, if adjustment or repairs are necessary, if any warning, operating or capacity label normally attached to the hoist is obscured, damaged, or missing. (See labels' list on page 35).

REPORT same promptly to your supervisor and also notify next operator, when changing shifts.

- (2)  **WARNING: SAFETY DEMANDS THAT YOU TEST THE SYSTEM BEFORE GOING ALOFT:**

- a) CHECK **PLATFORM** fully rigged and loaded by cycling UP and DOWN several times near ground level or safe surface.
- b) CHECK **PRIMARY BRAKE** for mechanical function: When stopping the hoist the load must be held immediately.
- c) CHECK **BSO SECONDARY BRAKE:**

I At ground level first close the BSO secondary brake by pushing EMERGENCY STOP button (d2). Then push control lever (d1) in DOWN-position and make the wire rope form a loop between tirak™ casing and BSO secondary brake (Fig. 23). Open BSO secondary brake by pulling down control lever (d1) until it locks in the open position.

With gloved hands sharply pull wire rope in arrow direction (Fig. 23) – the BSO secondary brake should close immediately (Fig. 24). Reset BSO secondary brake by pushing down control lever (d1) until it locks in the open position.

II Lift platform 3 ft. (1 m) above ground or safe surface, and push EMERGENCY STOP button (d2) of the BSO secondary brake (Fig. 24).

Lower the platform to check that the BSO secondary brake holds the load. A loop should form as shown in Fig. 23, which means the BSO secondary brake is supporting the load.

- 14 Raise platform until the hoist supports the load.

Figure 23

BSO Secondary Brake
Check I

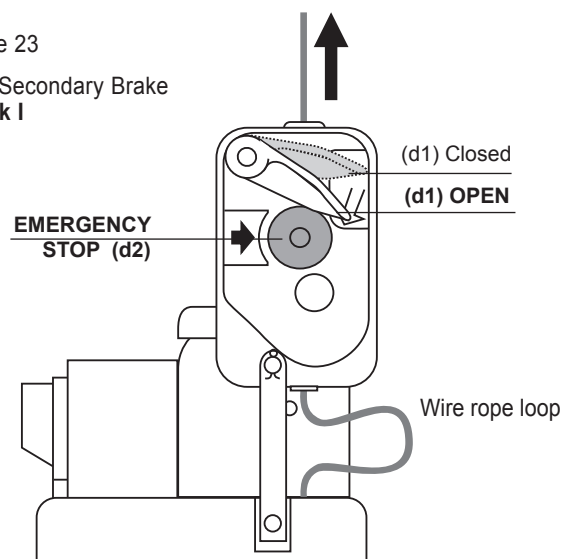
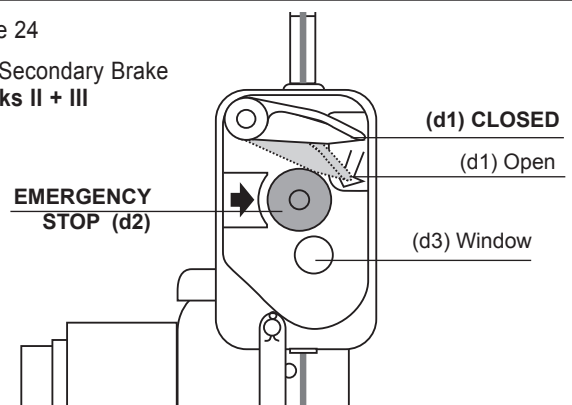


Figure 24

BSO Secondary Brake
Checks II + III



Reset (d1) to the open position.

- III During operation regularly check through the window (d3) that the centrifugal weights are rotating (Fig. 24).

WARNING:



IF DURING ONE OF THE CHECKS THE BSO SECONDARY BRAKE MALFUNCTIONS, IT MUST BE REPLACED.

- d) Check EMERGENCY STOP button and pushbutton control (Fig. 25)
- Check that the UP and DOWN pushbuttons return to their normal open position when released. They should move freely without sticking.
 - Push the red EMERGENCY STOP button. It should lock and remain depressed. Now try pushing the UP or DOWN pushbutton – the motor should not turn. Twist the EMERGENCY STOP button in the arrow direction to disengage it – it should pop out, and the hoist should now operate normally.

Repeat this check a few times to check function of pushbuttons and the EMERGENCY STOP.

The same procedure applies to hoists with pendant control.

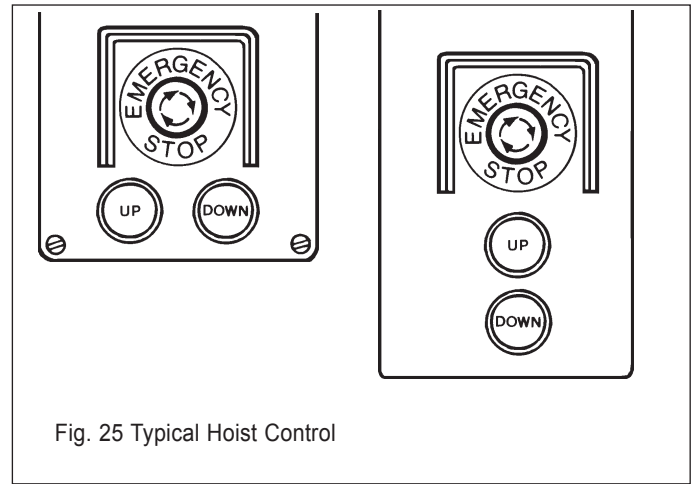


Fig. 25 Typical Hoist Control



WARNING:

If the pushbuttons or EMERGENCY STOP button do not function properly, remove hoist from service until repaired by a qualified person.

- CONTINUOUSLY CHECK rigging, lines, clearances, and all other elements throughout the entire time on the job.

5.2 Normal operation

- For **UP** and **DOWNWARD MOTION** of the platform just press the corresponding button.
- When operating platform, take care to operate hoists so that the platform stays level without tilting one end more than the other.

(3)  **WARNINGS**

- DO NOT** fix push-buttons in run position.
- DO NOT** operate the hoist, if it is functioning improperly, or damage is noted.
- NEVER** pick up a load beyond the rated capacity appearing on the hoist.
- STOP OPERATIONS IMMEDIATELY**, if at any time, when the hoist operates, the wire rope does not move (i.e. no UP or DOWN travel).
It is likely that damaged wire rope is jamming the hoist. Continued operation might cause wire rope failure or damage to the hoist. CONTACT the SUPPLIER!
- IN CASE OF AN INCIDENT** involving injury, or property damage, contact the supplier immediately.
DO NOT disturb, alter, or move any equipment at the scene of the incident.

- OPERATING IN EXPLOSIVE ATMOSPHERE:** Never operate hoist or any other electric equipment in a potentially explosive atmosphere – such as around distilleries, refineries, chemical plants, ship or silo interiors. Always obtain official approval before commencing operations at these or similar locations.

(4) **Special Operating Notes for Welding or Arc scarfing**

- ALWAYS PROTECT your equipment and yourself from the danger of arcing.
- BE SURE supporting equipment is grounded to prevent arcing across wire rope to the structure.
- DO NOT use wire rope as a ground for welding.
- DO NOT allow your welding gun to contact wire rope, hoist, or any other metal equipment or structure.
- PROTECT work area above and below hoist with insulation.
Split a section of air rubber hose, and wrap around wire ropes.
- Use an insulated thimble assembly to attach all wire rope(s) to the suspension system.

5.3 Emergency Descent

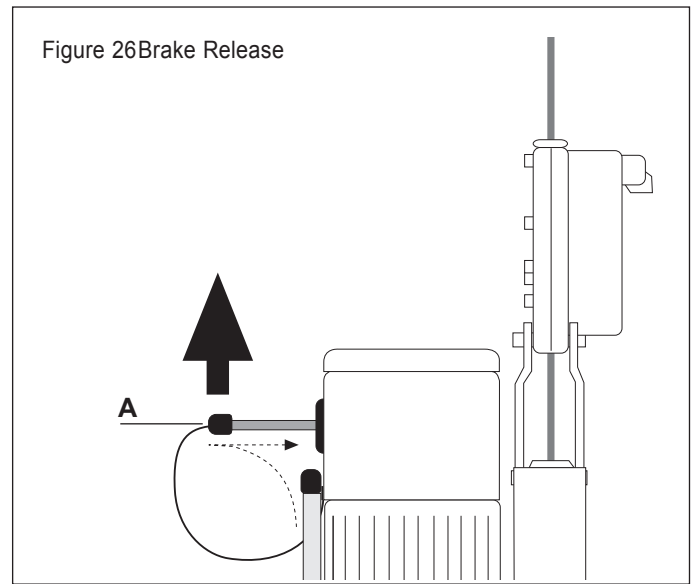
In case of emergency you can descend with the platform without power proceeding as follows:

- (1) Take the brake release lever (A) from the carrying handle, and insert it through the motor fan cover hole into the brake release bow. Lift in arrow direction (Fig. 26). The hoist begins to lower at moderate speed, which is regulated by a mechanical centrifugal brake.
- (2) To **STOP** just release the lever.
- (3) **After use:** restore brake release lever (A) into its storage position.



CAUTION:
DO NOT USE EMERGENCY DESCENT AS REGULAR TECHNIQUE TO LOWER.

NOTE: If during emergency descent the BSO Secondary brake closes, you have to wait for electric power to go up. The hoist must move up to get the BSO free. Reset BSO by pushing down control lever (d1) in open position (see Fig. 27). **DO NOT** force it open!



If electric power is not available you have to require help or a rescue!

WARNING:



If the BSO secondary brake stops downward travel during emergency descent, DO NOT DETACH BSO secondary brake FROM HOIST!

5.4 BSO Secondary Brake Action

(1) EMERGENCY STOP

Push EMERGENCY STOP button of the BSO Secondary brake, if – for whatever reason – you want to absolutely stop downward travel of the platform.

(2) To reset BSO secondary brake:

Raise the platform until the hoist supports the load.

Push the control lever in the OPEN position (d1) (Fig. 27). **DO NOT** force it open.

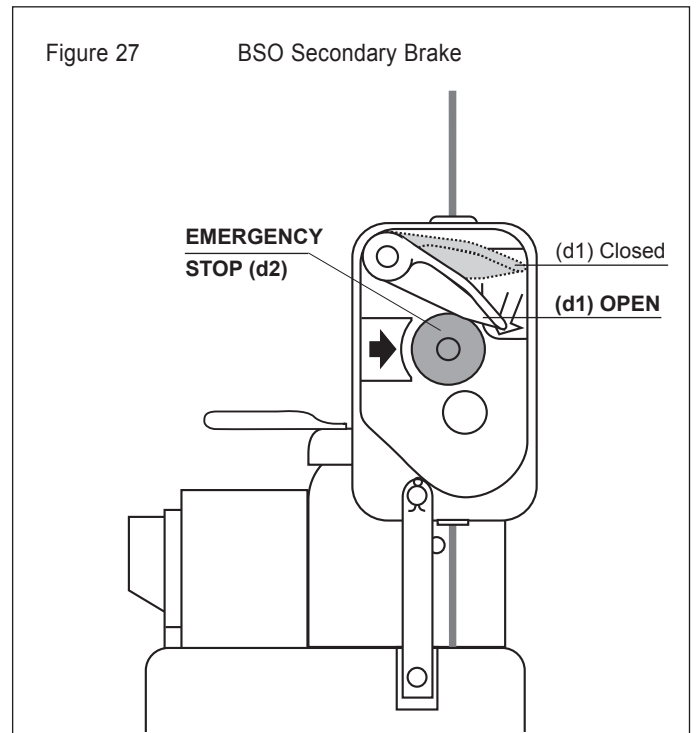
(3) If the BSO secondary brake has **automatically closed**:



WARNING: STOP DOWNWARD TRAVEL! YOU MAY HAVE RUN OFF THE WIRE ROPE CAUSING OVERSPEED. WITH EXTREME CAUTION TRY TO GO UP. IF YOU CANNOT GO UP, A RESCUE IS REQUIRED.

When the hoist supports the load, reset the BSO secondary brake as described above.

CAUTION: If the BSO secondary brake repeatedly stops downward travel, contact the supplier for advice. Check wire rope diameter (see page 11).



WARNING:
DURING USE OF THE HOIST NEVER DETACH BSO SECONDARY BRAKE!



WARNINGS!


Avoid injuries:

1. Checks and repair of the electric equipment must only be carried out by **QUALIFIED ELECTRICIANS!**
Wiring diagrams are found in the control box of the motor.

6. TROUBLE SHOOTING

2. **DO NOT OPEN ANY CONTROL BOX OR PENDANT CONTROL WITH POWER SUPPLY TO HOIST!**
3. Any other repair should only be carried out by the supplier (TRACTEL Group Company) or by a qualified person, and only original spare parts shall be used.

6.1 Wire Rope Drive Mechanism Troubles

Problem	Cause	Remedy
Wire rope does not move through, i. e. no UP nor DOWN movement.	It is likely that damaged wire rope is jamming the hoist.	 WARNING: STOP OPERATIONS IMMEDIATELY! Continued operation might cause wire rope failure. Contact the supplier.


6.2 Motor Troubles

Problem	Cause	Remedy
1. Motor does not run at all.	a) Power failure b) Incorrect wiring c) On 3 phase motor: stop by the phase control relay	a) Check fuses, power cords, connections, and starting capacitor. b) Compare wiring with wiring diagram. c) Check wiring.
2. Motor does not start with a load.	a) Overload b) Brake not released c) Voltage too low d) Incorrect wiring	a) Check load and reduce, if necessary. b) Check motor with brake released by hand. Check brake according to para. 5.1 (2), page 14. c) Check voltage when running the motor. Use power cord(s) with higher cross section. d) Compare wiring with wiring diagram.
3. Motor stalls under load.	Low voltage	Check voltage when running the motor. Use power cord(s) with higher cross sections.
4. Overheating when running without load	a) Insufficient cooling b) Incorrect wiring c) Voltage too high d) Short circuit in the coil	a) Clean motor fan cover. b) Compare wiring with wiring diagram. c) Check voltage and no-load current. d) Contact the supplier.
5. Overheating	a) Overload b) High or low voltage c) Starting capacitor still activated. Centrifugal switch defect. d) Crooked motor shaft. e) Brake not (correctly) released.	a) Check load and reduce if necessary. b) Check current consumption, and compare with motor label specifications. Check current and voltage. Check power cords c) Check current at the auxiliary winding in the control box, when running the motor. For centrifugal switch repair contact the supplier. d) Contact the supplier. e) Check brake according para. 6.3.
6. Abnormal motor noise	a) Electric parts (noise disappearing immediately, when stopping motor) b) Mechanical parts (noise continuous until hoist stands still)	a) Causes/remedies see above 1. to 5. b) Contact the supplier.

6.3 Primary Brake Troubles


Problem	Cause	Remedy
Brake does not open (lack of "click" switch noise, when starting/stopping the hoist)	a) Defective supply conductor, brake coil, rectifier. b) Worn brake rotor	a) Have supply conductor, current passage in brake coil, rectifier checked by an electrician or qualified person. b) Contact the supplier.

6.4 BSO Secondary Brake Troubles

Problem	Cause	Remedy
1. Hoist goes up but not down.	BSO secondary brake is closed: Primary wire rope has run out or has failed.	 WARNING: STOP DOWNWARD TRAVEL! Proceed according para. 5.4, (3), page 16.
2. BSO secondary brake automatically closes without apparent reason.	a) Mechanical defect. b) Oversized or damaged wire rope	a) Contact the supplier. b) Check wire rope and replace, if necessary.
3. Secondary brake will not	Frozen parts actuate manually.	DO NOT USE the unit until the brake has thawed, dried and is in proper condition. Thawing may be accomplished by blowing ducted dry heat (200 degrees F. max.) on the brake area. DO NOT USE OPEN FLAME!
4. Centrifugal weights do not turn or do not turn smoothly during operation.	Dirty, corroded, or worn parts.	Check operation through the sightglass. Do not use if operating improperly. Return unit to TRACTEL.

If you cannot find a trouble's cause, contact the supplier.

7. INSPECTIONS and MAINTENANCE

 **NOTE:** A maintenance program should start for each hoist immediately after it is entered into service.



Regular inspections should be followed for the life of the hoist and written inspection records kept as specified.

This maintenance program should comply with recommendations in the applicable parts and Instruction Manual, and all pertinent Federal, State, Provincial and Local regulations.

7.1 Inspections

7.1.1 DAILY INSPECTIONS

EACH DAY PRIOR TO USE AND DURING OPERATION CHECK:

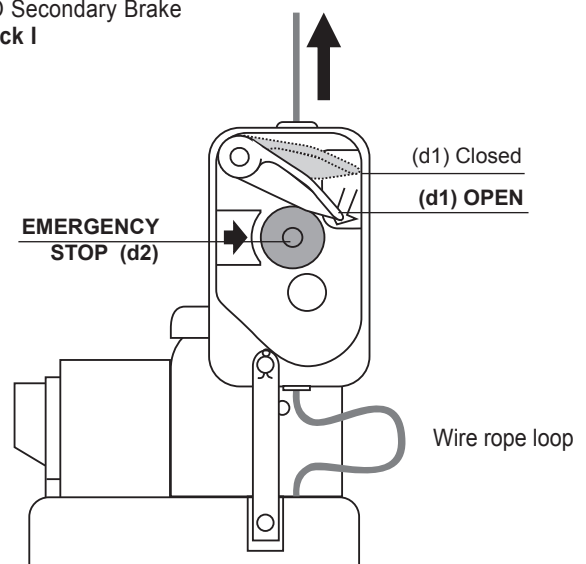
- (1) **Primary brake function:** "click" noise, when starting/stopping the hoist.
- (2) **blocstop BSO secondary brake function.**

I At ground level first close the BSO secondary brake by pushing EMERGENCY STOP button (d2). Then push Control lever (d1) in DOWN-position and make the wire rope form a loop between tirak™ casing and BSO secondary brake (Fig. 28). Open BSO secondary brake by pulling down control lever (d1) until it locks in the open position.

With gloved hands sharply pull wire rope in arrow direction (Fig. 28) – the BSO secondary brake should close immediately (Fig. 29). Reset BSO secondary brake by pushing down control lever (d1) until it locks in the open position.

Figure 28

BSO Secondary Brake
Check I



II Lift platform 3 ft. (1 m) above ground or safe surface, and push EMERGENCY STOP button (d2) of the BSO secondary brake (Fig. 29). Lower the platform to check that the BSO secondary brake holds the load. Raise platform until the hoist supports the load. Reset (d1) to the open position.

III During operation regularly check through the window (d3) that the centrifugal weights are rotating (Fig. 29).

- (3) **Wire rope:** free of kinks, cuts, broken wires, birdcages, heat damage, contamination etc.
- (4) **Wire rope corrosion** due to acid or caustics. Replace wire rope if exposed to these contaminants.
- (5) **Wire rope lubrication:** The wire rope has to be clean and lightly lubricated.
- (6) **Rigging**
Wire rope termination, connection to the suspension system. It must be aligned and secure.
- (7) Check for **parts damage**.



WARNING: If there is any: STOP working, unless the damaged part(s) is (are) replaced.

- (8) **Safety harness(es), lifeline(s), fall arrester(s) and lanyard(s) must be used at all times** in accordance with the requirements of OSHA regulations and state, provincial or local codes.

7.1.2 MONTHLY INSPECTIONS

- (1) All items under daily inspection.
- (2) Wire Rope Inspection

All wire rope should be inspected once a month, and a **signed and dated inspection record** maintained.

The inspection check list at back of this manual can be used to record these inspections.

WIRE ROPE SHOULD BE REPLACED, IF ANY OF THE FOLLOWING CONDITIONS ARE NOTED:

Conditions for replacing wire rope:

- Broken wires or strands.
- Excessive corrosion.
- Heat damage, evident through discolored wires.
- Reduction from nominal diameter of more than 5 %.
- Kinking, crushing, birdcaging, or any other distortion of the wire rope structure (Fig. 30).



NOTE: How to measure wire rope diameter:

The correct diameter of the wire rope is the largest cross-sectional measurement across the strands (and not the valleys).

The measurement should be made carefully with calipers as shown in Fig. 31.

Figure 29
BSO Secondary Brake
Check II + III

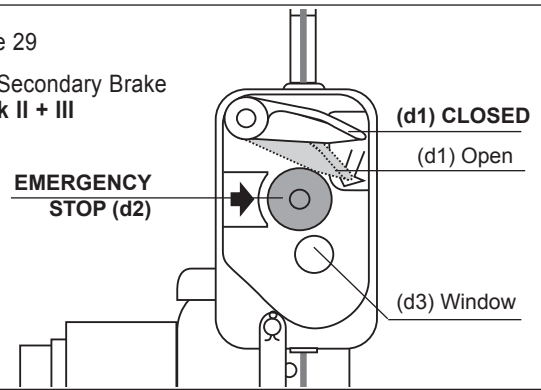


Figure 30 Examples of wire rope damage

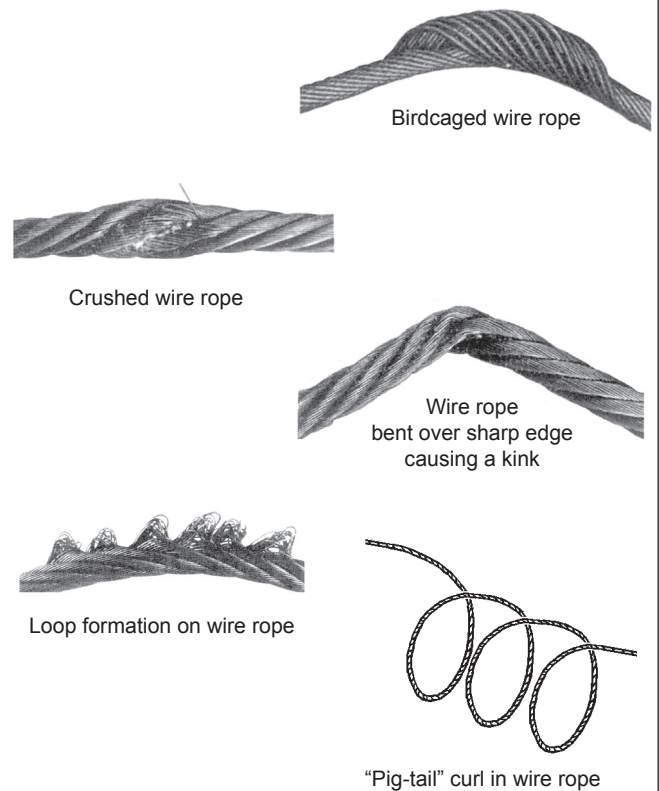
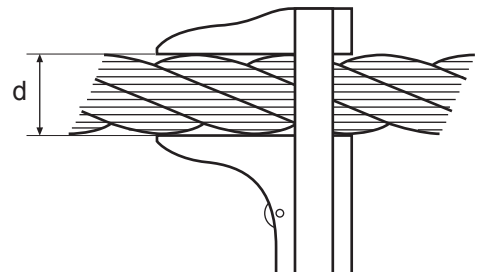


Figure 31 Checking Wire Rope Diameter "d"



WARNING: REPLACEMENT WIRE ROPE MUST BE SAME SIZE, GRADE, AND CONSTRUCTION AS THE WIRE ROPE SPECIFIED BY THE SUPPLIER! (See pages 7, 11)



THE SUPPLIER DECLINES ALL RESPONSIBILITY FOR MACHINES USED WITH A WIRE ROPE OTHER THAN SPECIFIED BY HIM.

7.1.3 Inspection, Maintenance & Testing

tirak™ hoists and blocstop™ BSO secondary brake shall be returned to an Authorized Tractel Repair Center for periodic maintenance after every job and at least after 250 hours of operation.

In any case, periodic maintenance must occur every 12 months/1 year from date of being put into service or 12 months/1 year from the date of the prior inspection.

tirak™ hoists and blocstop™ BSO secondary brake must be inspected more frequently and at least every 6 months if subjected to harsh or dirty environments or freezing conditions, or immediately if they fail any operation or inspection on job site.

In the event of an overspeed triggering of the blocstop™ BSO secondary brake during operation, damages to anchoring devices, wire rope and blocstop™ BSO secondary

brake are possible, and the blocstop™ BSO secondary brake must be immediately inspected by an Authorized Repair Center.




A signed and dated inspection record should be maintained for each tirak™ hoist and each blocstop™ BSO secondary brake device.

If a **gearbox oil change** is necessary, take one of the below specified oils according to the temperature range, the hoist usually will be used in.

Quantities required:

XE 300 P-Series:	1.4 litres
XE 500/600/700/1020/1030 P-Series:	2.0 litres
TE 1020 P-Series:	2.0 litres

Temperature range	14 to 122 degF -10 to +50 °C	-5 to 176 degF -15 to +80 °C	-31 to 104 degF -35 to +40 °C
API Specification	Mineral oils ³⁾ SAE85W-140 GL5 ¹⁾	Synthetic oils ³⁾ CLPPG or PGLP ISO VG 460 ²⁾ CLPPG or PGLP ISO VG 100	
Sample oils	BP Hypogear EP 90 SHELL Spirax HD 90 TEXACO Multigear EP6 S80 W90	Klübersynth GH6 460	Klübersynth GH6 100

 **NOTE: DO NOT use other oils without written authorization from the manufacturer or the supplier.**

- 1) Standard charge for XE 300/500/700 P and TE 1020 P series
(Marking: Socket head cap oil drain screw, Fig. 32)
- 2) Standard charge for XE 1020 P
(Marking: Yellow hexagon oil drain screw, Fig. 32)
- 3) Changing between mineral and synthetic oils requires complete cleaning of the gearbox parts.

7.2 Maintenance

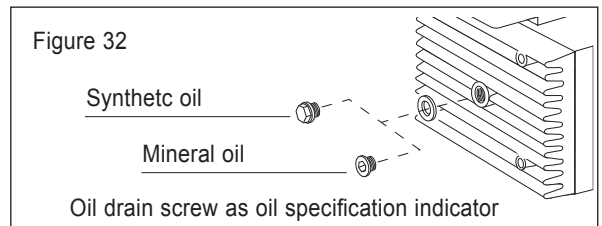
7.2.1 tirak™ Hoist

- (1) Daily check the primary and BSO secondary brake.
- (2) Daily check for visible part damage.
- (3) Keep wire ropes clean and lightly lubricated to prevent abnormal wear of the wire rope driving mechanism.

7.2.2 Wire Ropes

- (1) Use only wire ropes, which meet the manufacturers specifications. For details see pages 7 and 11.
This will ensure the reliable function of the hoist.
- (2) To warrant maximum lifetime we recommend:
 - The wire rope must be unreeled and reeled in a straight line.
 - Keep wire ropes clean.

Figure 32



- Lubricate wire ropes regularly with a rag soaked with oil.
- Never let the wire ropes rub against sharp edges.
- Always see that the wire rope outlet is not obstructed.
- Let the free wire rope end untwist to prevent wire rope from making loops.
- If the wire rope changes direction, it should be guided by sheaves or rollers to avoid damage.

7.2.3 blocstop™ BSO Secondary Brake

Besides the daily checks, keep all wire ropes clean and lightly lubricated.

Continue with chapters

- 8. NAMEPLATE & LABELS and**
- 9. WARRANTY INFORMATION**
- 10. ADDITIONAL SOURCES AND TRAINING**



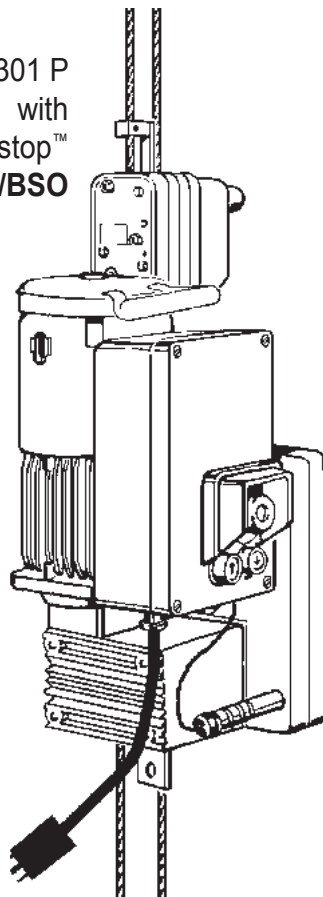
on pages 34 to 36

tirak™

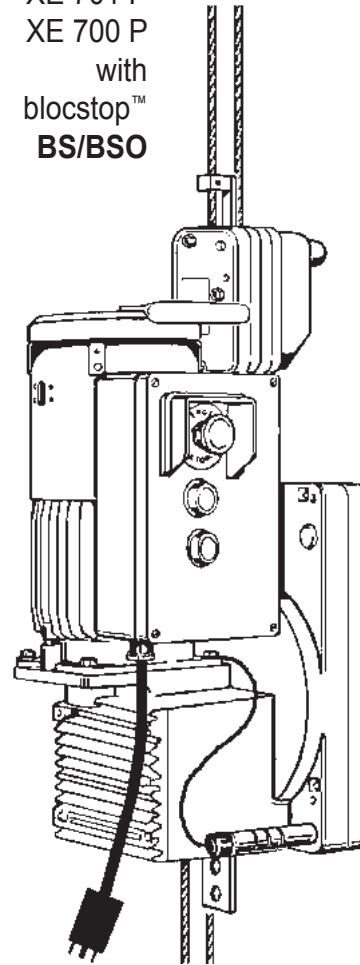
Scaffolding Hoist

Additional Instruction Manual for tirak™ hoists with 2 wire rope systems

XE 301 P
with
blocstop™
BS/BSO



XE 501 P
XE 501 PA
XE 500 P
XE 701 P
XE 700 P
with
blocstop™
BS/BSO



NOTE: The following part of this manual only contains instructions referring to the 2 wire rope system.



For all other instructions refer to pages 2 to 20.

TABLE OF CONTENTS of ADDITIONAL INSTRUCTIONS

A2. DESCRIPTION

A2.1 Two wire rope System	22
A2.2 Secondary Brake	22
A2.3 Wire Ropes	23
A2.7 Technical Data	24

A3. RIGGING INSTRUCTIONS

A3.1 General	
A3.1.1 Scope.....	25
A3.1.2 Checks before rigging.....	25

A4. WIRE ROPE

A4.2 Wire Rope Rigging Instructions.....	26
A4.3 Wire Rope Reeving.....	27
A4.4 De-rigging	29

A5. OPERATING INSTRUCTIONS

A5.1 General.....	29
A5.3 Emergency Descent	30
A5.4 Secondary Brake Action	31

A6. TROUBLE SHOOTING

A6.4 BS/BSO Secondary Brake	32
-----------------------------------	----

A7. INSPECTIONS and MAINTENANCE

A7.1 Inspections	
A7.1.1 Daily Inspections	33
A7.2 Maintenance	
A7.2.1 tirak™ Hoist	34
A7.2.2 Wire Ropes	34
A7.2.3 blocstop™ BS/BSO Secondary Brake.....	34

INTRODUCTION

1. GENERAL WARNING

(See pages 3 to 5)

A2. DESCRIPTION

A2.1 Two wire rope System

tirak™ hoists (A) with blocstop™ BS/BSO overspeed and slack wire rope locking device (E) – here-after called BS/BSO secondary brake – are principally used with **two wire ropes** (see Fig. 33):

- The tirak™ hoist goes up and down the **primary wire rope (P)**.
- The BS/BSO secondary brake works on both the **primary wire rope (P)** and the **secondary wire rope (S)** as described below.

A2.2 Secondary Brake

In case of accelerating overspeed the blocstop™ BS/BSO secondary brake stops the descent immediately **on the primary wire rope (P)**.

In case of slack primary wire rope or primary wire rope failure BS/BSO secondary brake stops the descent by immediately locking **on the secondary wire rope (S)**.

THE SECONDARY BRAKE MUST ALWAYS BE ATTACHED AND USED.

NOTE: IF for any reason a **SECONDARY ROPE IS NOT RIGGED** and used, the BS/BSO secondary brake functions the same as a BSO secondary brake, and **THIS SECTION IS NO LONGER APPLICABLE.**



A2.3 Wire Ropes



CAUTION:

It is mandatory that both the **PRIMARY AND THE SECONDARY WIRE ROPE MEET THE MANUFACTURERS SPECIFICATIONS!**

only this special tirak™ wire rope may be used.

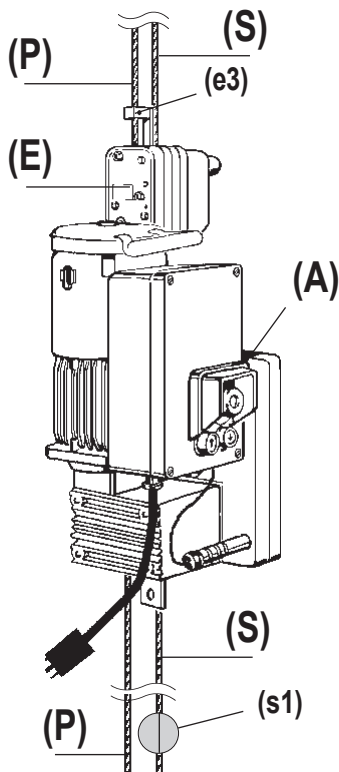
NOTE: The manufacturer declines all responsibility for machines used with a wire rope other than specified by them.



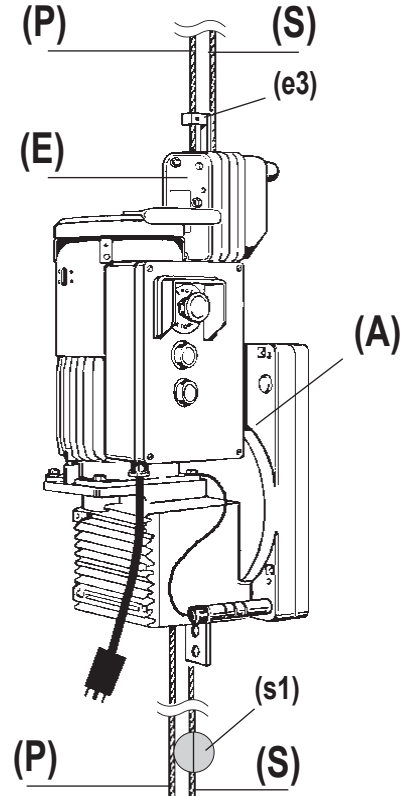
For details see pages 7 and 11.

Unless specifically specified in writing by the manufacturer,

Figure 33



XE 301 P
with blocstop™ BS/BSO



XE 500/700 P series
with blocstop™ BS/BSO

- A** tirak™ Hoist
- E** blocstop™ BS/BSO secondary brake
 - e1 Control lever
 - e2 EMERGENCY STOP on the blocstop
 - e3 Release lever for slack wire rope locking device
- P** Primary wire rope
- S** Secondary wire rope
 - s1 Tensioning weight for secondary wire rope

(for more details see Fig. 2, page 6)

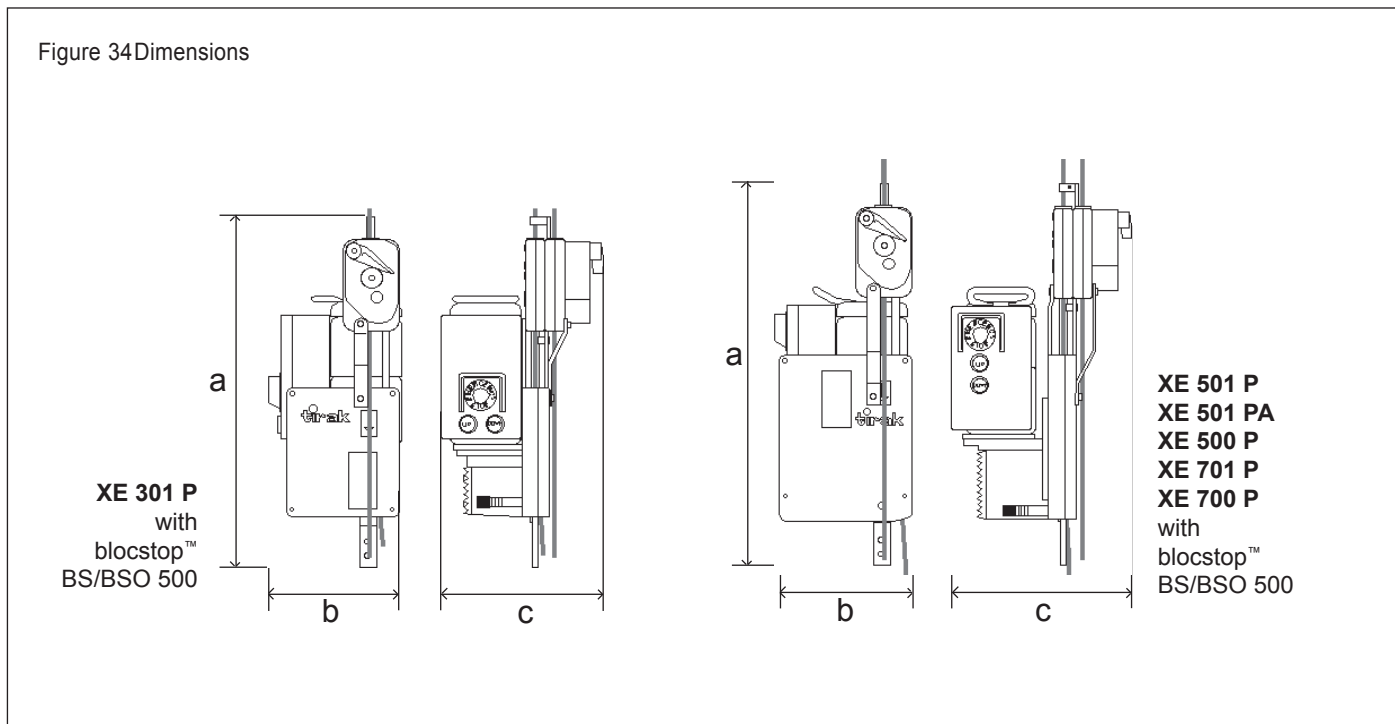
For detailed info about

- **Motor and Primary Brake,**
- **Gear Reducer,**
- **Emergency Descent without power,**
- and
- **Wire Rope Driving Mechanism**

see page 6.

A2.7 Technical Data

Figure 34 Dimensions



Hoist Model		XE 301 P	XE 501 P	XE 501 PA	XE 500 P	XE 701 P	XE 700 P	
Rated load	lbs	700	1,000	1,000	1,000	1,500	1,500	
	kg	315	450	450	450	680	680	
Lifting speed	ft/min	33	35	35	35	35	35	
	m/min	10	11	11	11	11	11	
Weight (with BS/BSO)	lbs	88	130	128	112	130	119	
	kg	40	59	58	51	59	54	
Dimensions over all	a	in.	30.7	33.5	33.5	33.5	33.5	
		mm	779	852	858	858	858	852
	b	in.	11.3	12.9	12.5	12.1	12.5	12.5
		mm	286	328	318	308	318	318
	c	in.	13.8	17.3	15.5	15.5	15.5	15.5
		mm	351	439	394	394	394	394
Motor specifications		electrical motor						
3-phase 220 V/60 cycles	kW	–	–	–	1.1	–	1.5	
	A	–	–	–	4.5	–	6.1	
single phase:								
110 or 220 V/ 60 cycles	kW	0.55	1.1	–	–	–	–	
	A	10.0/4.8	19.0/8.5	–	–	–	–	
220 V/ 60 cycles	kW	–	–	1.1	–	1.5	–	
	A	–	–	8.5	–	12.0	–	
wire rope diameter	in. mm	5/16 8.4						

wire rope classification/construction		5 x 19, 4 x 26, or 5 x 26, with fiber core, or 6 x 19, (min. 17 wires per strand), galvanized or black, lubricated, preformed, IPS or XIPS
nominal diameter	in./mm	5/16 in. / 8.4 mm
maximum allowed diameter tolerances	in. mm	0.319 to 0.331 8.1 to 8.4
minimum actual breaking strength	lbs kN	10,000 44.5

CAUTION:



Correct wire rope diameter is very important for the tirak™ function! An oversized wire rope may cause a wire rope jam inside the hoist and/or the BSO or BS/BSO secondary brake to malfunction.

A3. RIGGING INSTRUCTIONS

A3.1 GENERAL

A3.1.1 Scope

Instructions and advice of this part of the manual exclusively refer to the following items (see Fig. 35):

- **tirak™ scaffold hoist** with **blocstop™ BS/BSO secondary brake**;
- **PRIMARY and SECONDARY special tirak™ wire ropes**.

A3.1.2 Checks before rigging

It is a qualified person's responsibility to check the whole installation to meet all safety requirements of:

- OSHA regulations and federal, state, provincial or local safety regulations,
- the proper instructions delivered by the manufacturers of the other pieces of equipment included in your suspended scaffold installation.

Some pieces are:

- Support equipment including **tie-backs** for both the **equipment itself and the secondary wire rope**;
- platform system, work-cage, or bosun's chair;
- safety equipment;
- barricade below the drop of the platform/work-cage/bosun's chair.

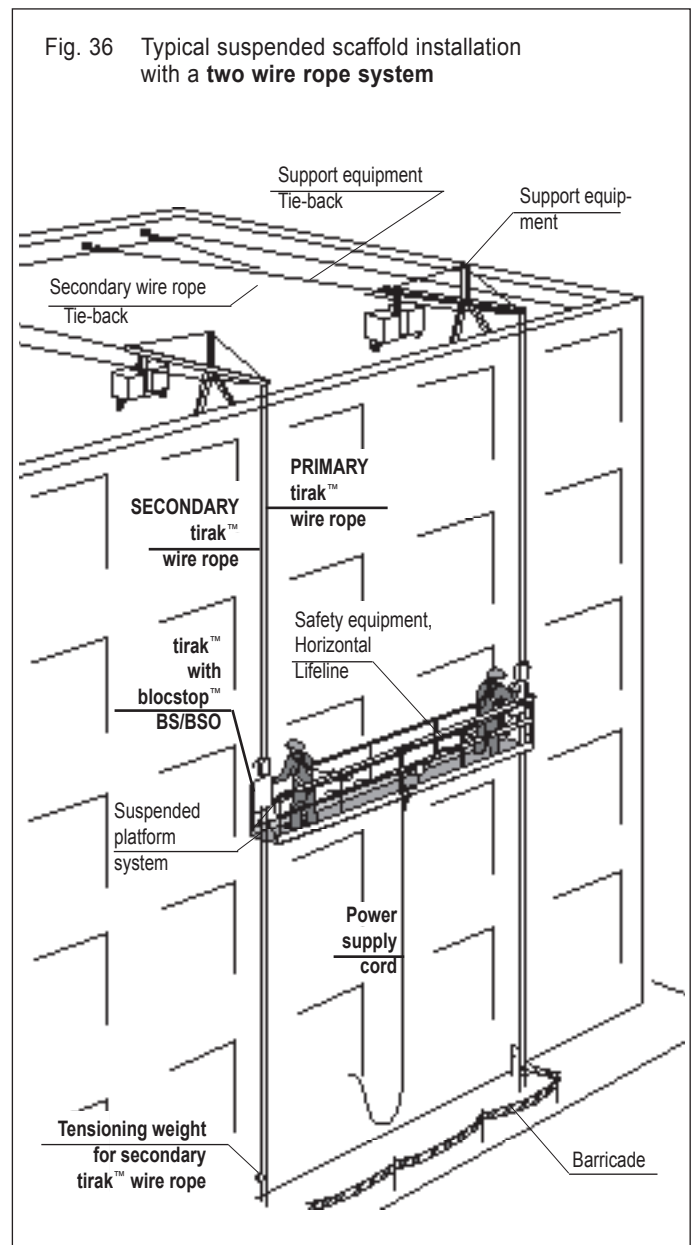
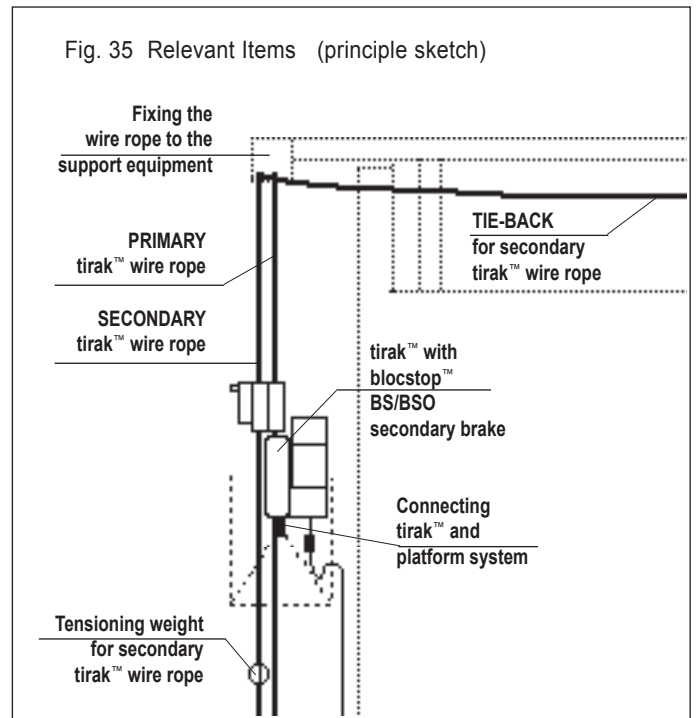
NOTE: This information is **NOT to be considered** as a complete checklist for your specific installation. It is only a sample list of some general components, which make part of a typical suspended scaffold installation with a **two wire rope system** (Fig. 36).



3.2 Power Supply and Hoist Control and

3.3 Hoist Mounting

(see pages 9 to 10)



A4. Wire Rope

4.1 Wire rope specification

(see pages 7 and 11)

A4.2 Wire rope rigging instructions

CAUTION:



Be sure to use wire rope according to specification (see pages 7, 11), with the diameter (d) (Fig. 37) marked on the **tirak™** nameplate for both the **PRIMARY** and the **SECONDARY** wire rope.

(1) RIG FROM TOP.

You should have enough wire rope to reach to the ground or other safe level with about five feet (1.5 m) extra for ensuring safety.

CAUTION:



Always unreel and reel the wire rope in a straight line (Fig. 38) to prevent kinks, which make it unusable for the hoist.

(2) If the wire rope is not equipped with a swaged fitting

as shown in Fig. 39, proceed as follows:

- Install heavy duty thimble with a minimum of three (3) J-Type (Fist Grip) Clamps (Fig. 40).
- Apply first clamp approximately 7" (18 cm) from thimble. Tighten nuts moderately.
- Attach second clamp as close to thimble as possible. Leave nuts loose.
- Attach the third clamp half-way between first and second clamp, leaving the nuts loose. Take up wire rope slack.
- Tighten nuts evenly on all clips (approx. 30 ft-lbs. torque) as specified by the clamp manufacturer.

WARNINGS:



- a) Retighten after the wire rope is loaded for the first time
- b) Inspect fastening periodically.

In use, wire ropes will stretch and reduce in diameter.
Retighten all "Fist Grip" nuts periodically.

(3) Anchor the wire rope ends (Fig. 41) to a rigging device, which complies with all relevant safety requirements.

Figure 37 Checking Wire Rope Diameter "d"

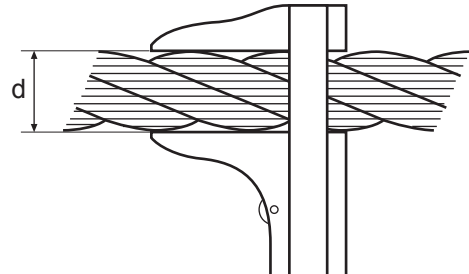


Figure 38 Wire Rope Handling

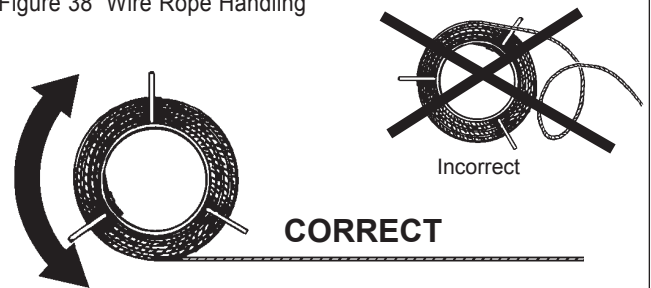


Figure 39

Wire Rope Termination by Swaged Fitting

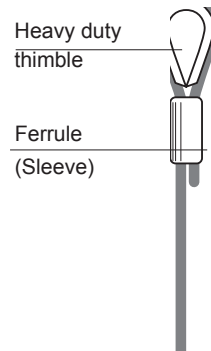
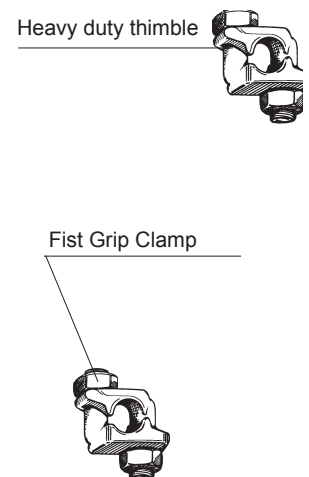


Figure 40

Wire Rope Termination by Fist Grip Clamps



Be sure to use compatible connecting devices, e. g. a 1/2 in. anchor shackle or similar with adequate strength and safety factor. Secure it.

Distance (a) between the wire ropes:

approx 1 1/2 in. / 40 mm.

CAUTION:



Secondary wire rope anchoring must be connected to a tie back (Fig. 42).

(4) Insure that the anchor points of the wire rope are directly above the position of the hoists (Fig. 17 on page 12).

WARNING:



Improper spacing is dangerous and could cause failure of the support system.

(5) Check that wire rope tip is to be welded round (Fig. 18 on page 12).

A4.3 Wire rope reeving

NOTE: Ensure both wire ropes hang parallel from the suspension point.



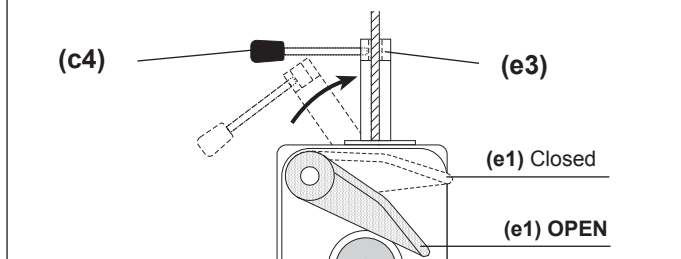
A4.3.1 Primary wire rope (P)

(1) Open the BSO secondary brake by pushing down the control lever (e1) until it locks (Fig. 43). Push and hold release lever (e3) in its vertical position (use brake release lever (c4) to ease the operation) to ease insertion of primary wire rope.



CAUTION: Check that wire rope exit (C) is not blocked in any manner.

Fig. 43 Opening of BS/BSO secondary Brake



(2) With gloved hands slide the rope through release lever hole and push it through the BSO secondary brake at (A) into the hoist rope inlet (B). Push it inside, and press UP button, until the wire rope reeves itself automatically and exits at (C) on the other side (Fig. 44).

d) Let the primary wire rope run through until it is tensioned.

Never load the wire rope exiting from (C), by applying a weight to, or tensioning.

Fig. 41 Wire Rope Anchoring

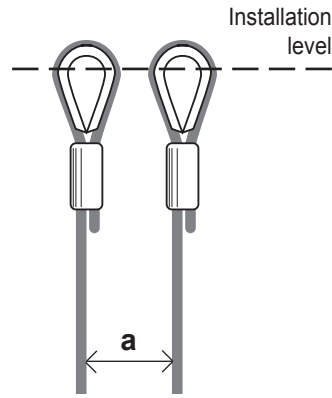


Fig. 42 (principle drawg.)

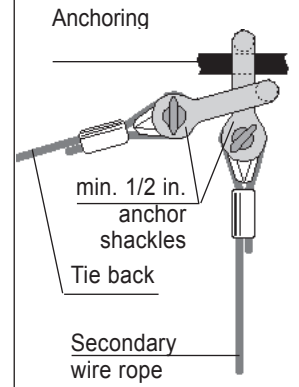
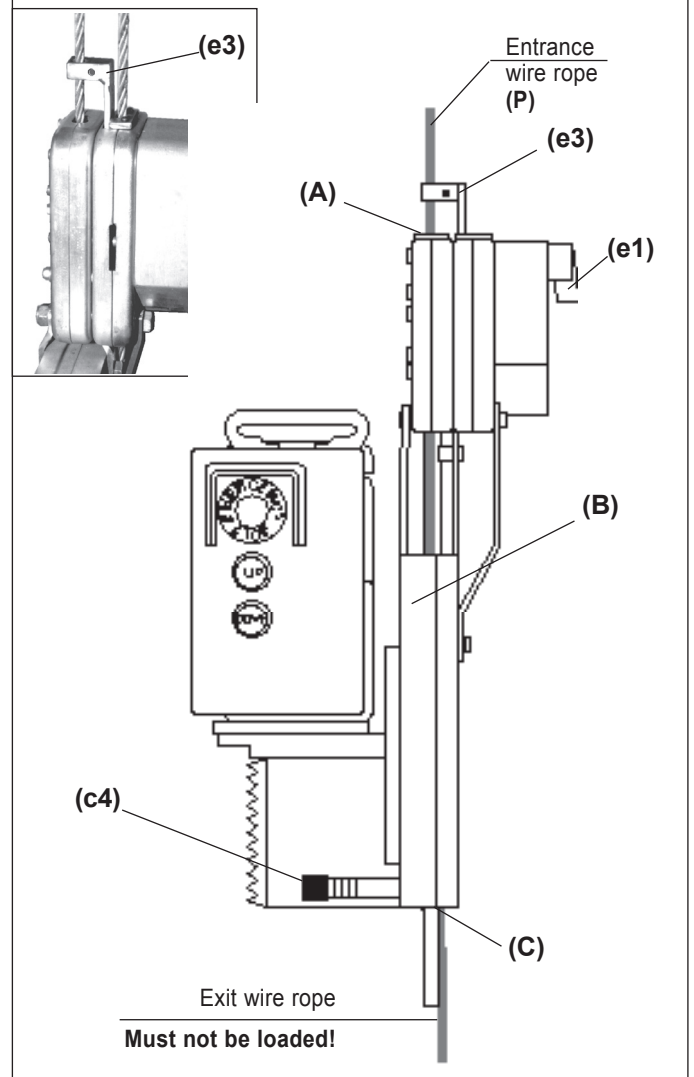


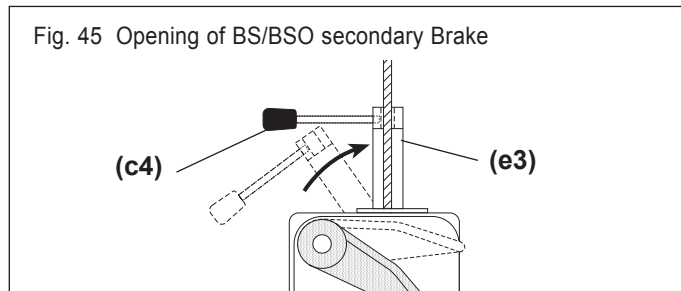
Fig. 44 Primary Wire Rope Reeving

(Principle drawing valid for all tirak™ seires)



A4.3.2 Secondary wire rope (S)

- (1) BS/BSO secondary brake should be opened by the primary wire rope under load. Otherwise push and hold release lever (e3) in its vertical position (Fig. 45).

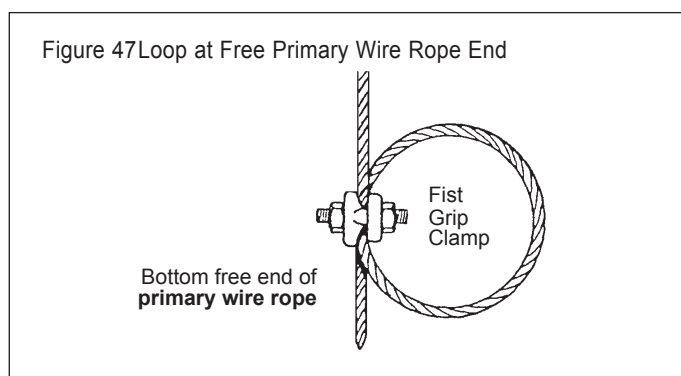


- (2) Insert secondary wire rope at (D), on T-series into rope guiding device (E), and push through until it is tensioned (Fig. 46).
- (3) Above ground level fix a tensioning weight (s1) of approx. 25 lbs. (10 kgs) to the lower end of the secondary wire rope (Fig. 46). This weight will help to pull the secondary wire rope through the BS/BSO secondary brake and avoid slack wire rope above the hoist, which could be dangerous in the event of fall.
- (4) Take precautions to make sure tensioning weight (s1) will not damage property or create a hazard by swinging freely.

A4.3.3 Primary Wire Rope End

After primary wire rope reeving through the hoist, be sure to loop and clamp the free end of the wire rope to prevent the rope from inadvertently unreeving through the hoist.

Always tie this loop, using a fist grip clamp, when the platform is at ground level (Fig. 47).

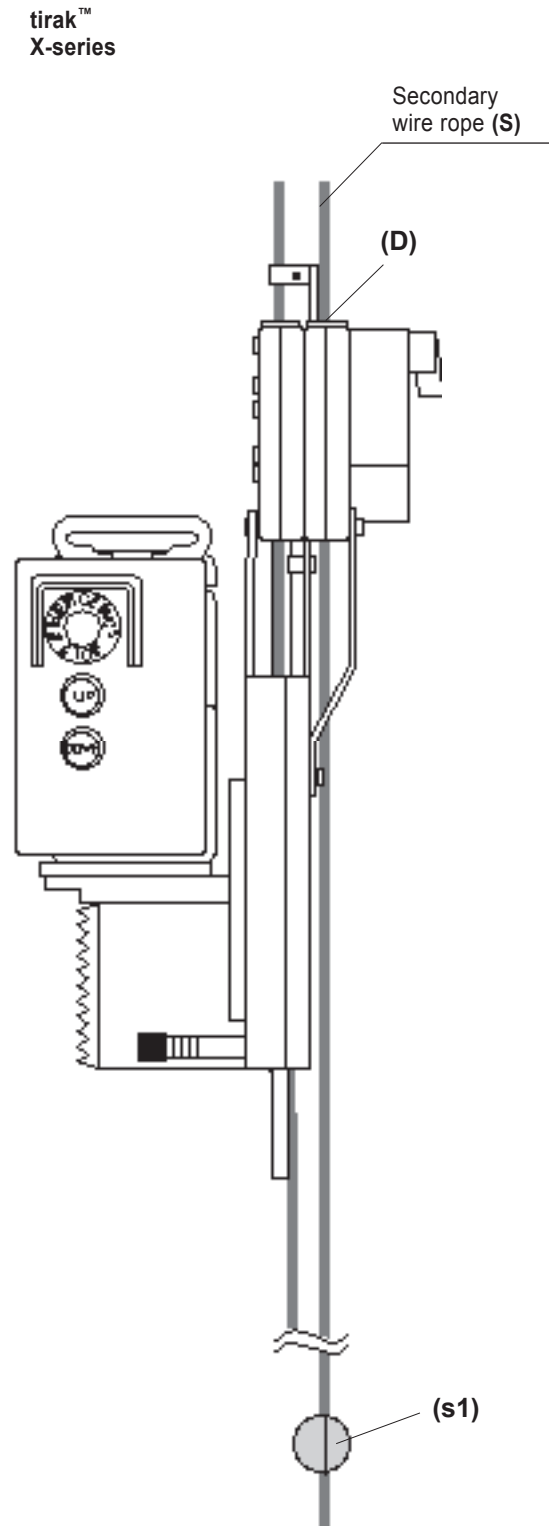


WARNING:



AT EVERY SET-UP OR RE-RIGGING check the wire rope length to ensure that it reaches the ground or other safe level with about five feet (1.5 m) extra for safety.

Figure 46 Secondary Wire Rope Reeving



A4.4 De-Rigging

A4.4.1 Secondary wire rope

- (1) Lower the platform until it almost reaches its safe and stable support. Leave the primary wire rope tensioned so that the release lever (e3) of BS/BSO secondary brake is still upright.
- (2) Remove the tensioning weight (s1).
- (3) If **release lever (e3)** is not held in its **open** position by the tensioned primary wire rope, hold it in its open position by using brake release lever (c4) according to Fig. 45 to ease operation.
- (4) With gloved hands pull out the secondary wire rope.

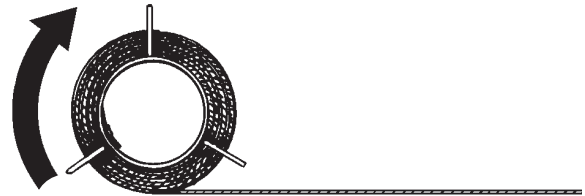
A4.4.2 Primary wire rope

- (1) Lower the platform to a safe and stable support until each tirak™ hoist is unloaded.
- (2) Remove the loop at the free wire rope end.
- (3) Press DOWN button to let the wire rope run out. As soon as the suspension wire rope is not under load, hold **release lever (e3)** of BS/BSO secondary brake in its open position by using brake release lever (c4) according to Fig. 45 to ease operation.
- (4) With gloved hands slowly pull the primary wire rope through BS/BSO secondary brake.

A4.4.3 Wire Rope Storage

Clean the wire ropes, reel them (Fig. 48), and store them in a clean and dry place.

Figure 48 Wire Rope Handling



A5. Operating Instructions

A5.1 GENERAL

- (1) BE FAMILIAR with the equipment and its proper care.

DO NOT operate hoist, if adjustment or repairs are necessary, if any warning, operating or capacity instructions normally attached to the hoist are obscured, damaged, or missing. (See labels' list on page 34).

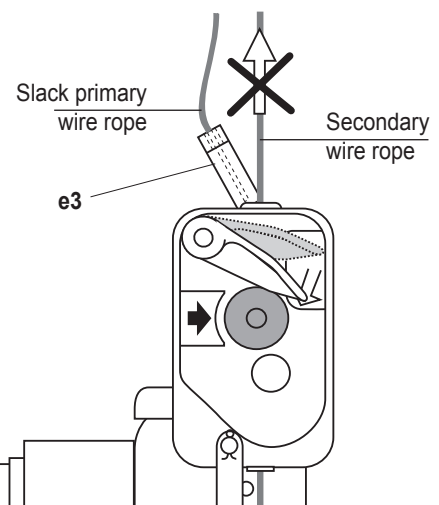
REPORT same promptly to your supervisor and also notify next operator, when changing shifts.

- (2)  **WARNING: SAFETY DEMANDS THAT YOU TEST OUT THE SYSTEM BEFORE GOING ALOFT:**

- a) CHECK **PLATFORM** fully rigged and loaded by cycling UP and DOWN several times near ground level or safe surface.
- b) CHECK **PRIMARY BRAKE** for mechanical function: When stopping the hoist the load must be held immediately.
- c) CHECK **BS/BSO SECONDARY BRAKE:**
 - I At ground level push DOWN button to get slack primary wire rope – release lever (e3) tilts to

Figure 49

BS/BSO Secondary Brake
Check I



the side to close BS/BSO secondary brake for the secondary wire rope (Fig. 49).

With gloved hands try to pull the secondary wire rope upwards: it **must be impossible**.

c) CHECK **BS/BSO SECONDARY BRAKE:**
(continued)

II At ground level first close the BSO secondary brake by pushing EMERGENCY STOP button (e2). Then push Control lever in DOWN-position and make the wire rope form a loop between tirak™ casing and BSO secondary brake (Fig. 50). Open BSO secondary brake by pulling down control lever (e1) until it locks in the open position.

Push release lever (e3) in its upright position and with gloved hands sharply pull primary wire rope in arrow direction (Fig. 50) – the BS/BSO secondary brake should close immediately (Fig. 51).

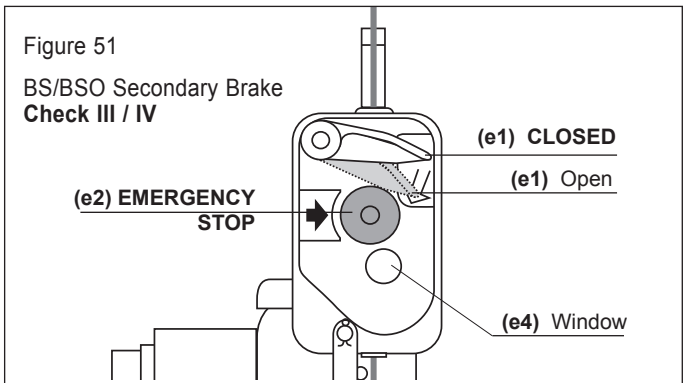
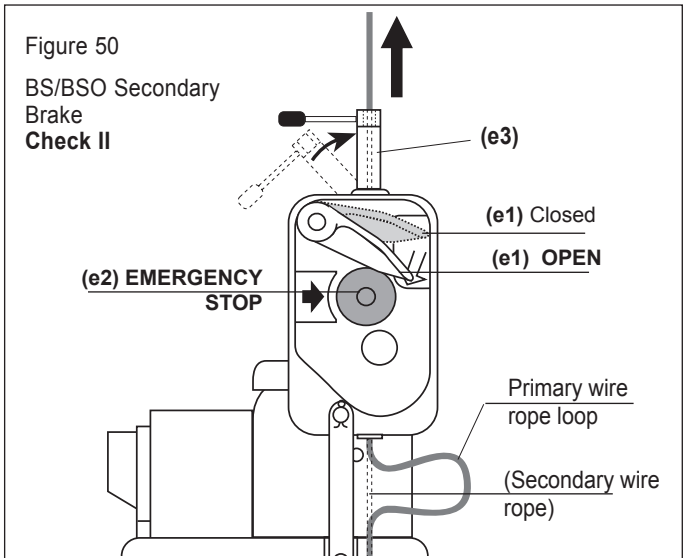
Reset BSO secondary brake by pushing down control lever (e1) until it locks in the open position.

III Lift platform 3 ft. (1 m) above ground or safe surface, and push EMERGENCY STOP button (e2) of the BS/BSO secondary brake (Fig. 51).

Lower the platform to check that the BS/BSO secondary brake holds the load. A loop should form as shown in Fig. 50, which means the BS/BSO is supporting the load.

Raise platform until the hoist supports the load. Reset (e1) to the open position.

IV During operation **regularly check** through the window (e4) that the centrifugal weights are rotating (Fig. 50).



WARNING: IF DURING ONE OF THE CHECKS THE BS/BSO SECONDARY BRAKE MALFUNCTIONS, IT MUST BE REPLACED.



d) Check EMERGENCY STOP but-

ton and push-button control according to page 12.

e) CONTINUOUSLY CHECK rigging, lines, clearances, and all other elements throughout the entire time on the job.

5.2 Normal operation

(see page 15)

A5.3 Emergency Descent

In case of emergency you can descend with the platform without power proceeding as follows:

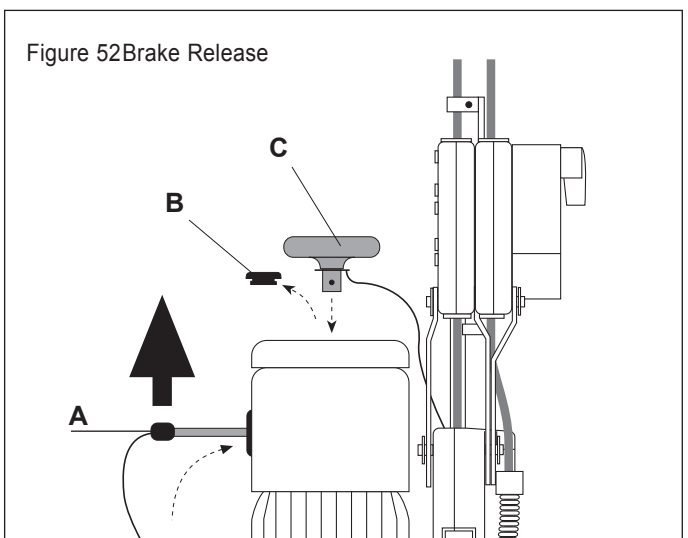
(1) Take the brake release lever (A) from the carrying handle, and insert it through the motor fan cover hole into the brake release bow. Lift in arrow direction (Fig. 52). The hoist begins to lower at moderate speed, which is regulated by a mechanical centrifugal brake.

(2) To **STOP** just release the lever.

(3) **After use:** restore brake release lever (A) into its storage position.



CAUTION: DO NOT USE EMERGENCY DESCENT AS REGULAR TECHNIQUE TO LOWER.



If during emergency descent the BS/BSO secondary brake has been activated, it could be because:

CASE (A): The **BSO overspeed device** has locked on the primary rope.

CASE (B): The **BS slack wire rope device** has locked on the secondary wire rope.
(Platform hits obstruction during descent)

To unlock BS/BSO secondary brake proceed as follows:

- Remove rubber cap (B) from motor fan cover, take hand wheel (C) from its support on the tirak™ casing, and place it on the motor shaft (Fig. 52).

- With the **brake opened** (see above) turn the hand wheel clockwise (T-series) resp. counter-clockwise (X-series) until the hoist supports the load.

- **CASE (A):** Reset BSO overspeed device by pushing down control lever (e1) until it locks in the open position (Fig. 50).

- **CASE (B):** The BS slack wire rope device is automatically opened by the transfer of the load to the primary wire rope.

- Restore hand wheel (C) into its storage position, and put back rubber cap (B) on the motor fan cover.

- Continue with manual descent.

A5.4 BS/BSO Secondary Brake Action

(1) EMERGENCY STOP

Push EMERGENCY STOP button of the BS/BSO Secondary brake, if – for whatever reason – you want to absolutely stop downward travel of the platform.

(2) To reset BS/BSO secondary brake:

Raise the platform until the hoist supports the load.

Push the control lever in the OPEN position.

DO NOT force it open.

(3) If the BS/BSO secondary brake has **automatically closed on the primary wire rope**, i. e. control lever (e1) has returned to **CLOSED** position (Fig. 51):

CASE (A)



WARNING: STOP DOWNWARD TRAVEL! YOU MAY HAVE RUN OFF THE PRIMARY WIRE ROPE CAUSING OVER-SPEED. WITH EXTREME CAUTION TRY TO GO UP. IF YOU CANNOT GO UP, A RESCUE IS REQUIRED.

When the hoist supports the load, reset the BS/BSO secondary brake as described above.

CASE (B)



WARNING: STOP DOWNWARD TRAVEL! THE PRIMARY WIRE ROPE HAS FAILED. RESCUE IS REQUIRED.

(4) If the BS/BSO secondary brake has **automatically closed on the secondary wire rope**, i. e. **release lever (e3) is tilted** because of slack primary wire rope (Fig. 53):



WARNING: STOP DOWNWARD TRAVEL! THE PLATFORM HAS HIT AN OBSTRUCTION PREVENTING DOWNWARD MOVEMENT.

GO UP UNTIL THE HOIST SUPPORTS THE LOAD – the tensioned primary wire rope automatically re-opens the BS/BSO secondary brake for the secondary wire rope to move again freely through the device.

CLEAR THE OBSTRUCTION and descend.

CAUTION: If the BS/BSO secondary brake repeatedly stops downward travel, contact the supplier for advice.



WARNING:

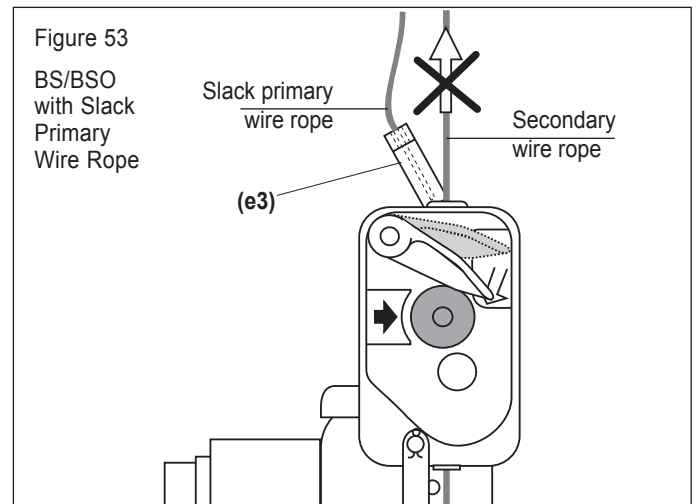


Figure 53

BS/BSO with Slack Primary Wire Rope

Slack primary wire rope

Secondary wire rope

(e3)



DURING USE OF THE HOIST NEVER DETACH BS/BSO SECONDARY BRAKE!

A6. TROUBLE SHOOTING

WARNINGS!



Avoid injuries:

1. Checks and repair of the electric equipment must only be carried out by **QUALIFIED ELECTRICIANS!** Wiring diagrams are shown in the control box of the motor.

2. **DO NOT OPEN ANY CONTROL BOX OR PENDANT CONTROL WITH POWER SUPPLY TO HOIST!**
3. Any other repair should only be carried out by the supplier (TRACTEL Group Company) or by a qualified person, and only original spare parts shall be used.

6.1 Wire Rope Drive Mechanism Troubles

6.2 Motor Troubles

(see pages 16 to 17)

6.3 Primary Brake Troubles

A6.4 BS/BSO Secondary Brake Troubles

Problem	Cause	Remedy
1. Hoist goes up but not down	BS/BSO secondary brake is closed a) Primary wire rope has run out or has failed. b) Platform has hit an obstruction	a) WARNING: STOP DOWNWARD TRAVEL! Proceed according para. A5.4, (3), page 30. b) WARNING: STOP DOWNWARD TRAVEL! Go up until the hoist supports the load, and clear the obstruction. Details in para A5.4, (4), page 31.
2. BS/BSO secondary brake automatically closes without apparent reason.	a) Mechanical defect. b) Oversized or damaged wire rope	a) Contact the supplier. b) Check wire rope and replace, if necessary.
3. Unit will climb but will not descend.	Closed Secondary Brake	Power up approximately 6 inches while depressing. bloctest TM control lever to open.
4. Excessive wire rope wear.	a) Worn Guide Bushing. b) Rigging	a) Replace inlet and outlet bushings if worn. b) Rigging alignment - wire rope must pass straight through hoist, not at an angle.

If you cannot find a trouble's cause, contact the supplier.

A7. INSPECTIONS and MAINTENANCE

NOTE: A maintenance program should start for each hoist immediately after it is entered into service. This maintenance program should comply with recommendations in the applicable parts and Instruction Manual, and all pertinent Federal, State, Provincial and Local regulations.



Regular inspections should be followed for the life of the hoist and written inspection records kept as specified.

A7.1 Inspections

A7.1.1 DAILY INSPECTIONS

EACH DAY **PRIOR TO USE** AND DURING OPERATION CHECK:

- (1) **Primary brake function:**
“click” noise, when starting/stopping the hoist.
- (2) **blocstop BS/BSO secondary brake function.**
 - I At ground level or on a safe surface push DOWN button to get slack in the primary wire rope: release lever (e3) tilts to the side to close BS/BSO secondary brake on the secondary wire rope (Fig. 54).
With gloved hands try to pull the secondary wire rope upwards: it **must be impossible**.
 - II At ground level first close the BSO secondary brake by pushing emergency stop button (d2). Then push Control lever in DOWN-position and make the wire rope form a loop between tirak™ casing and BSO secondary brake (Fig. 55). Open BSO secondary brake by pulling down control lever (e1) until it locks in the open position.
Push release lever (e3) in its upright position and with gloved hands sharply pull wire rope in arrow direction (Fig. 54) – the BS/BSO secondary brake should close immediately (Fig. 56). Reset BS/BSO secondary brake by pushing down control lever (e1) until it locks in the open position.
 - III Lift platform 3 ft. (1 m) above ground or safe surface, and push EMERGENCY STOP button (e2) of the BS/BSO secondary brake (Fig. 56).
Lower the platform to check that the BS/BSO secondary brake holds the load. A loop should form as shown in Fig. 55, which means the BS/BSO is supporting the load.
Raise platform until the hoist supports the load.
Reset (e1) to the open position.
 - IV During operation regularly check through the window (e4) that the centrifugal weights are rotating (Fig. 56).
- (3) **Wire rope:** free of kinks, cuts, broken wires, bird-cages, heat damage, contamination etc.
- (4) **Wire rope corrosion** due to acid or caustics. Replace wire rope if exposed to these contaminants.
- (5) **Wire rope lubrication:** The wire rope has to be clean and lightly lubricated.
- (6) **Rigging**
Wire rope termination, connection to the suspension system. It must be aligned and secure.
- (7) Check for **parts damage**.



WARNING: If there is any: **STOP working, unless the damaged part(s) is (are) replaced.**

Figure 54

BS/BSO Secondary Brake
Check I

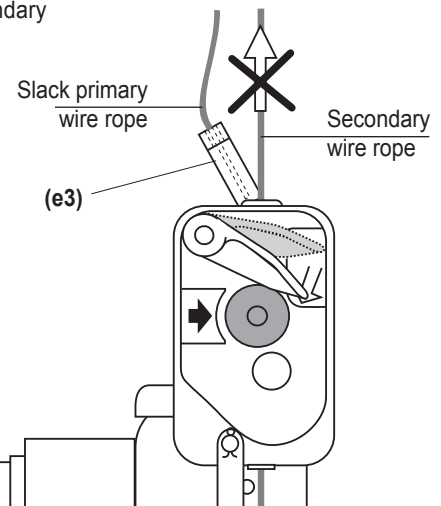


Figure 55

BS/BSO Secondary Brake
Check II

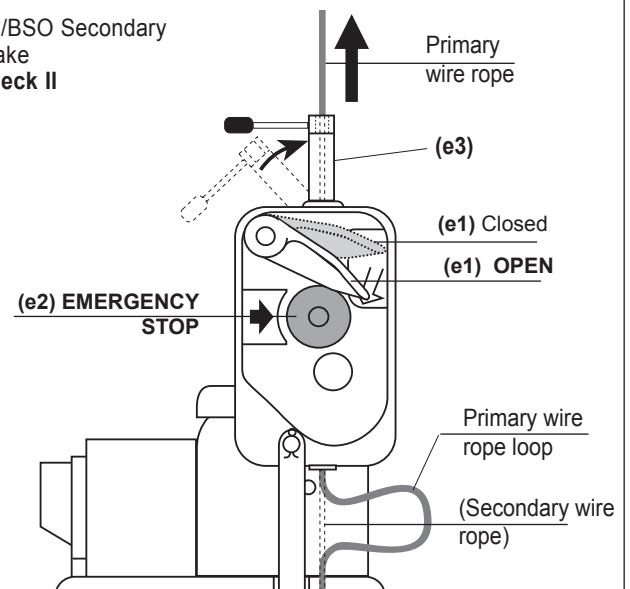
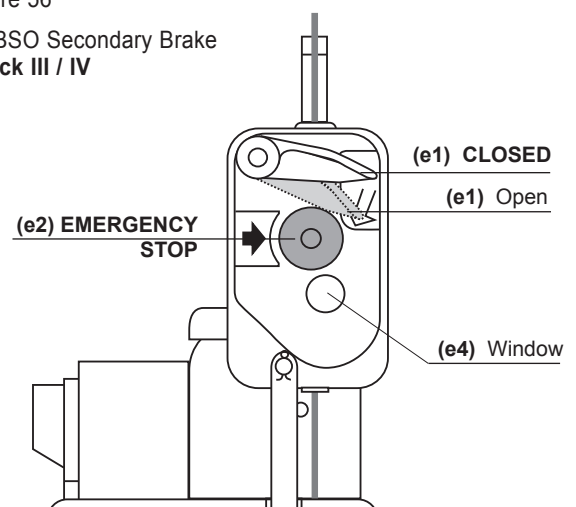


Figure 56

BS/BSO Secondary Brake
Check III / IV



- (8) **Safety harness(es), lifeline(s), fall arrester(s) and lanyard(s) must be used at all times** in accordance with the requirements of OSHA regulations and state, provincial or local codes.

7.1.2 MONTHLY INSPECTIONS

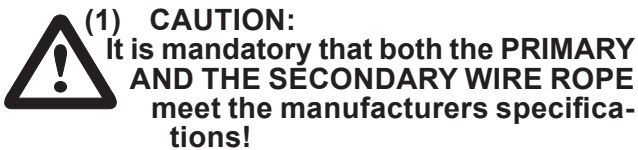
7.1.3 Inspection, Maintenance & Testing (see page 19)

A7.2 Maintenance

A7.2.1 tirak™ Hoist

- (1) Daily check the primary and BS/BSO secondary brake.
- (2) Daily check for visible part damage.
- (2) Keep wire rope clean and lightly lubricated to prevent abnormal wear of the wire rope driving mechanism.

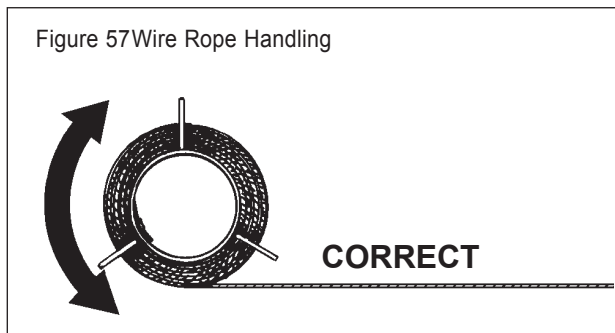
A7.2.2 Wire Ropes



For details see pages 7 and 11.

This ensures the reliable function of the hoist.

- (2) To warrant maximum lifetime we recommend:
 - The wire rope must be unreeled and reeled in a straight line (Fig. 57).



- Keep wire ropes clean.
- Lubricate wire ropes regularly with a rag soaked with oil.
- Never let the wire ropes rub against sharp edges.
- Always see that the wire rope outlet is not obstructed.
- Let the free wire rope ends untwist to prevent wire rope from making loops.
- If the wire rope changes direction it should be guided by sheaves or rollers to avoid damage.

A7.2.3 blocstop™ BS/BSO Secondary Brake

Besides the daily checks, keep all wire rope clean and lightly lubricated.

8. NAMEPLATES & LABELS

8.1 Nameplates

- 1 tirak™ nameplate
- 2 Motor nameplate
- 3 Primary brake nameplate
- 4 blocstop™ Secondary brake nameplate

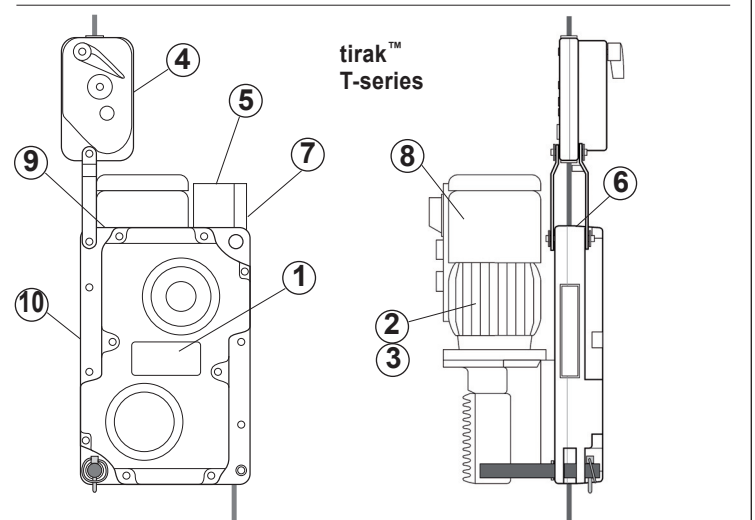
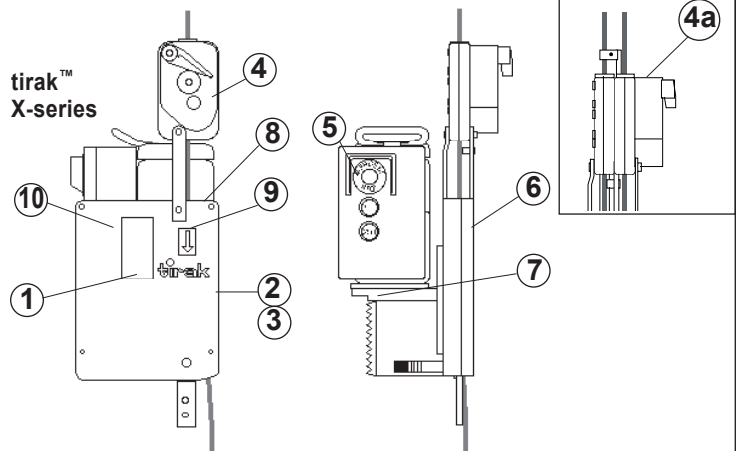
8.2 Labels

- 4a Advice label (additional secondary brake check)
- 5 Warning label (wire rope jam)
- 6 Advice label (secondary brake operation)
- 7 General Warning & Advice label
- 8 Emergency Descent label
- 9 Wire rope diameter label
- 10 UL classification label



NOTE: If any nameplate or label is missing or obscured, contact the supplier for replacement nameplates/labels.

Figure 58 Nameplates and Labels



1

tirak™ Made in Germany

Model

Rated load:	lbs	kg
Travel speed:	ft/min	m/min
Operating voltage:	Current consumption:	
	WAC	phase A

Do not let the voltage of motor terminals drop below motor nameplate rating under load.

Serial No.: _____ Year of manufacture: **20** / _____

Wire rope diameter: in. mm

Wire rope classification/construction: 6x19 or 6x25 with fiber core, galvanized, lubricated, pretensioned, XPG.

Use only wire rope as specified by the hoist manufacturer!

8 270-0411 105970

Code 105850

2

TRACTEL GREIFZUG GmbH Bergisch Gladbach

Type	Nr.		
E-Mot.	Hz	U _{min}	
kW	cos φ		
V	A		
Schalt.	Schutzart IP 55	Is.KI.	

Code 16206


3

TRACTEL GREIFZUG GmbH Bergisch Gladbach

Bremstyp			
Leistung	W	Spulenspannung	V
Moment	Nm		

Code 16706

5

 **If the motor energizes but the wire rope does not move through the hoist: STOP THE HOIST IMMEDIATELY!**

Damaged wire rope may be jammed inside the hoist. Any attempt to move the hoist up or down could cause a dangerous situation and result in bodily injury.

Code 22080

6

 **NOTICE:** This hoist is equipped with a controlled descent device that will automatically engage in case of primary brake failure. Descent can be stopped with manual operation of the secondary brake.

Code 22230

4

blocstop™
secondary brake

Model		Serial number	
BSO			
Rated load	Wire rope Ø	Year of manuf.	
kg lbs.	mm in.	201	

CHECKING

1) Before using, daily check as follows:

- With no load applied, form a bow in the wire rope between the blocstop™ secondary brake and its anchor points. With gloved hands sharply pull wire rope away from the blocstop™ anchor point – the blocstop™ secondary brake should close immediately.
- Lift platform or load 3 ft (1 m) above ground or safe surface, and push **EMERGENCY STOP** button of the blocstop™ secondary brake. Lower the platform or load to check that the blocstop™ secondary brake holds the load. Raise platform or load until the hoist supports the load. Reset blocstop™ secondary brake by pushing control lever until it locks open.

2) During operation centrifugal weights must rotate. Check regularly through the window.

WARNING: If during the above checks the blocstop™ secondary brake malfunctions, replace it and return to the supplier for inspection. Address see tirak™ hoist nameplate.

8 270-0411 105970 Made in Germany

Code 105970

blocstop™
wire rope gripping safety

Model

BSO

Serial number

Stopping load

kg lbs.

Wire rope Ø

mm in.

Year of manuf.

201

Tripping speed

m/min ft/min (+/- 10 % tolerance)

8 271-0411 108140 Made in Germany

Code 108140

CHECKING

1) Before using, daily check as follows:

- With no load applied, form a bow in the wire rope between the blocstop™ safety device and its anchor points. With gloved hands sharply pull wire rope away from the blocstop™ anchor point – the blocstop™ safety device should close immediately.
- Lift platform or load 3 ft (1 m) above ground or safe surface, and push **EMERGENCY STOP** button of the blocstop™ safety device. Lower the platform or load to check that the blocstop™ safety device holds the load. Raise platform or load until the hoist supports the load. Reset blocstop™ safety device by pushing control lever until it locks open.

2) During operation centrifugal weights must rotate. Check regularly through the window.

WARNING: If during the above checks the blocstop™ safety device malfunctions, replace it and return to the supplier for inspection. Address see tirak™ hoist nameplate.

4a

ADDITIONAL CHECKING

At ground level push **DOWN** button to get slack primary wire rope – release lever tilts to the side to close BS/BSO secondary brake for the secondary wire rope.

With gloved hands try to pull the secondary wire rope upwards: it must be impossible.

Code 22050

7



WARNING:

Only authorized, properly trained, and physically fit personnel shall operate this hoist in strict accordance with the instructions on the hoist and applicable codes! Copy of instructions must be kept with the hoist.



Operating WARNING:

Immediately STOP RUNNING THE HOIST, if wire rope does not move through.

EMERGENCY DESCENT: Take brake release lever out of tirak™ handle, and insert in motor cover hole. Push lever upwards. To STOP release lever.

CAUTION: The tirak™ can only be used in conjunction with the **blocstop OVER-SPEED** device, which is an integral part of the equipment. Use of this equipment is unsafe and unlawful without proper fall protection equipment used in accordance with OSHA requirements.

SET-UP INSTRUCTIONS: Anchor the hoist, and connect to electric supply. Red button must be out to start the motor. Start motor, and introduce wire rope, until it reeves itself automatically.

Ensure free rope exit.

Use only specified wire rope in good condition with short tapered end! **Daily check** for broken wires and kinks.

For spare parts or in case of inquiry please mention **Machine Type and Serial No.!**

G442-03/01 Printed in Germany

Code 22510

8



Notablaß

Bremslüfterhebel im Handgriff

Emergency Descent

Brake release lever in TIRAK handle

Descente d'urgence

Manette de commande du frein dans la poignée de portage

G 207-09/94

Code 22220

9

Wire rope
Ø
5/16"

Code 27660

Wire rope
Ø
3/8"

Code 27670

Wire rope
Ø
13/32"

Code 100630

On tirak™ XE 300 P-series XE 500/600/700 P-series	On tirak™ XE 720/721 P XE 1020 P TE 1020 P	On tirak™ XE 1030 P
---	---	------------------------

10



Classified by Underwriters Laboratories Inc.® as to load capacity, electrical fire and shock hazards only.

400 S G 212-10/01

Code 22240

9. WARRANTY INFORMATION

- (1) TRACTEL INC. warrants its equipment to be free from defects in material and workmanship under normal use and service.
- (2) Our obligation under this warranty is limited to repairing or replacing, at our option, any part of the unit, which proves examination to our satisfaction to be defective in material or workmanship, if the item in question is returned through a TRACTEL INC. distributor, transportation prepaid, within one (1) year from the equipment is sold to the original purchaser¹⁾. Return shipment must be prepaid.
- (3) Any parts proved to be defective upon our inspection will be repaired or replaced at no cost for the parts themselves.
- (4) The obligation under this warranty does not include labor or travelling costs, or consequential damages of any kind.
- (5) Any defect in this equipment must immediately be brought to attention of the distributor from whom the unit was purchased. The distributor will make arrangements with the factory for repairs or replacement of parts within the terms of this warranty.
- (6) TRACTEL INC.'s obligation is limited to replacing parts and does not include replacing the complete unit. This warranty is void on any unit that has been modified or tampered with, repaired by persons other than a factory representative or an authorized TRACTEL INC. distributor, repaired with other than TRACTEL INC. standard parts, or damaged by reasons of accident, alteration, misuse, or abuse.
- (7) This warranty is in lieu of all other warranties, expressed or implied. We do not authorize any person or representative to make other guarantee or to assume for us any liability in connection with the sale of our appliances other than those contained herein. Any agreement outside of or contradictory to the foregoing shall be void and of no effect.

1) "Original purchaser" definition:
for rental machines: Dealer,
for resale machines: First user.

10. ADDITIONAL SOURCES AND TRAINING

The Scaffold Industry Association Inc.
offers a certificated training course for suspended scaffold users.

Information may be obtained from

Scaffold Industry Association Inc.
20335 Ventura Blvd. Suite 310
Woodlands Hills, California 91364

Telephone: (818) 610-03 20
Fax: (818) 610-03 23
www.scaffold.org
e-mail: sia@scaffold.org

GIVE TO SCAFFOLD ERECTOR & USER OR POST ON JOB

CODE OF SAFE PRACTICES FOR SUSPENDED POWERED SCAFFOLDS

It shall be the responsibility of all employers and users to read and comply with the following common sense

guidelines, which are designed to promote safety in the erection and use of suspended powered scaffolds. These guidelines do not purport to be all-inclusive nor to supplant or replace other additional safety and precautionary measures to cover usual or unusual conditions.

If these guidelines conflict in any way with any state, local or federal statute or governmental regulation, said statute or regulation shall supersede these guidelines. It is the responsibility of each user to comply with these guidelines.

I. GENERAL GUIDELINES

- A. POST THESE SAFETY GUIDELINES in a conspicuous place and be sure that all persons who erect, use, locate, or dismantle suspended scaffold systems are fully aware of them.
- B. FOLLOW ALL EQUIPMENT MANUFACTURERS' RECOMMENDATIONS as well as all state, local and federal codes, ordinances and regulations relating to suspended powered scaffolding.
- C. SURVEY THE JOBSITE.
A survey shall be made of the jobsite for hazards such as exposed electrical wires, obstructions that could overload or tip the suspended powered scaffold when it is raised or lowered, unguarded roof edges or openings, inadequate or missing tiebacks. Those conditions should be corrected before installing or using suspended powered scaffold systems.
- D. INSPECT ALL EQUIPMENT BEFORE EACH USE.
Never use any equipment that is damaged or defective in any way. Tag damaged or defective equipment and remove it from the jobsite.
- E. ERECT AND DISMANTLE SUSPENDED POWERED SCAFFOLD EQUIPMENT in accordance with design and/or manufacturer's recommendations.
- F. DO NOT ERECT, DISMANTLE, OR ALTER SUSPENDED POWERED SCAFFOLD SYSTEMS unless under the supervision of a competent person.
- G. DO NOT ABUSE OR MISUSE SUSPENDED POWERED SCAFFOLD EQUIPMENT.
Never overload platforms or hoists.
- H. ERECTED SUSPENDED POWERED SCAFFOLDS SHOULD BE CONTINUOUSLY INSPECTED by the user to ensure that they are maintained in a safe condition. Report any unsafe condition to your supervisor.
- I. NEVER TAKE CHANCES! IF IN DOUBT REGARDING THE SAFETY OR USE OF SUSPENDED SCAFFOLDS, CONSULT YOUR SCAFFOLD SUPPLIER.
- J. NEVER USE SUSPENDED SCAFFOLDS EQUIPMENT FOR PURPOSES OR IN WAYS FOR WHICH IT WAS NOT INTENDED.
- K. CARE SHOULD BE TAKEN WHEN OPERATING AND STORING EQUIPMENT DURING WINDY CONDITIONS.
- L. SUSPENDED POWERED SCAFFOLD SYSTEMS should be installed and used in accordance with the manufacturer's recommended procedures. Do not alter components in the field.
- M. SUSPENDED POWERED PLATFORMS MUST NEVER BE OPERATED NEAR LIVE POWER LINES, unless proper precautions are taken. Consult the power service company for advice.
- N. ALWAYS ATTACH FALL ARREST EQUIPMENT when working on suspended powered scaffolds.
- O. DO NOT WORK ON OR INSTALL SUSPENDED POWERED SCAFFOLDS if your physical condition is such that you feel dizzy, or unsteady in any way.
- P. DO NOT WORK ON SUSPENDED POWERED SCAFFOLDS when under influence of alcohol or illegal drugs.

II. GUIDELINES FOR ERECTION AND USE OF SUSPENDED SCAFFOLD SYSTEMS.

A. RIGGING:

1. WEAR FALL PREVENTION EQUIPMENT when rigging on exposed roofs or floors.
2. ROOF HOOKS, PARAPET CLAMPS, OUTRIGGER BEAMS, OR OTHER SUPPORTING DEVICES must be capable of supporting the hoist machine rated load with a factor of safety of 4.
3. VERIFY THAT THE BUILDING OR STRUCTURE WILL SUPPORT the suspended loads with a factor of safety of 4.
4. ALL OVERHEAD RIGGING must be secured from movement in any direction.
5. COUNTERWEIGHTS USED WITH OUTRIGGER BEAMS must be of a non-flowable material and must be secured to the beam to prevent accidental displacement.
6. OUTRIGGER BEAMS THAT DO NOT USE COUNTERWEIGHTS must be installed and secured on the roof structure with devices specifically designed for that purpose. Direct connections shall be evaluated by a competent person.
7. TIE BACK ALL TRANSPORTABLE RIGGING DEVICES. Tiebacks shall be equivalent in strength to suspension ropes.
8. INSTALL TIEBACKS AT RIGHT ANGLES TO THE FACE OF THE BUILDING and secure, without slack, to a structurally sound portion of the structure, capable of supporting the hoisting machine rated load with a safety factor of 4. IN THE EVENT TIEBACKS CANNOT BE INSTALLED AT RIGHT ANGLES, two tiebacks at opposing angles must be used to prevent movement.
9. RIG AND USE HOISTING MACHINES DIRECTLY UNDER THEIR SUSPENSION POINTS.

B. WIRE ROPE AND HARDWARE:

1. USE ONLY WIRE ROPE AND ATTACHMENTS as specified by the hoisting machine manufacturer.
2. ASSURE THAT WIRE ROPE IS LONG ENOUGH to reach to the lowest possible landing.
3. CLEAN AND LUBRICATE WIRE ROPE in accordance with the wire rope manufacturer's instructions.
4. HANDLE WIRE ROPE WITH CARE.
5. COIL AND UNCOIL WIRE ROPE in accordance with the wire rope manufacturer's instructions in order to avoid kinks or damage.
6. TIGHTEN WIRE ROPE CLAMPS in accordance with the clamp manufacturer's instructions.
7. DO NOT USE WIRE ROPE THAT IS KINKED, BIRD-CAGED, CORRODED, UNDERSIZED, OR DAMAGED IN ANY WAY. Do not expose wire rope fire, undue heat, corrosive atmospheres, electricity, chemicals, or damage by tool handling.
8. USE THIMBLES AND SHACKLES AT ALL WIRE ROPE SUSPENSION TERMINATIONS.
9. USE J-TYPE CLAMPS OR SWEDGE FITTINGS.
Do not use U-bolts.
Retighten J-Clamps under load and retighten daily.
10. WIRE ROPES USED WITH TRACTION HOISTS MUST HAVE PREPARED ENDS. Follow manufacturer's recommendations.

C. POWER SUPPLY:

1. GROUND ALL ELECTRICAL POWER SOURCES AND POWER CORD CONNECTIONS and protect them with circuit breakers.
2. USE POWER CORDS OF THE PROPER WIRE SIZE THAT ARE LONG ENOUGH for the job.
3. POWER CORD CONNECTIONS MUST BE RESTRAINED to prevent their separation.
4. USE STRAIN RELIEF DEVICES TO ATTACH POWER CORDS TO THE SUSPENDED SCAFFOLD to prevent them from falling.
5. PROTECT POWER CORDS AT SHARP EDGES.
6. USE GFI WITH POWER TOOLS.

D. FALL ARREST EQUIPMENT:

1. EACH PERSON ON A SUSPENDED POWERED SCAFFOLD must be attached to a separate fall arrest system unless the installation was specifically designed not to require one.
2. EACH LIFELINE MUST BE FASTENED to a separate anchorage capable of holding a minimum of 5000 pounds.
3. DO NOT WRAP LIFELINES AROUND STRUCTURAL MEMBERS unless lifelines are protected and a suitable anchorage connection is used.
4. PROTECT LIFELINES AT SHARP CORNERS to prevent chafing.
5. RIG FALL ARREST SYSTEMS to prevent free fall in excess of six feet.

6. SUSPEND LIFELINES FREELY without contact with structural members or building facade.
7. USE LIFELINES OF SIZE AND CONSTRUCTION that are compatible with the rope grab used.
8. ASSURE A PROPERLY ATTACHED ROPE GRAB IS INSTALLED ON EACH LIFELINE. Install in accordance with the manufacturer's recommendations.
9. KEEP FALL ARREST DEVICE POSITIONED ABOVE YOUR HEAD LEVEL.
10. USE ONLY FULL BODY HARNESSES of the proper size and that are tightly fastened.
11. ASSURE FULL BODY HARNESS HAS LANYARD **attachment** with D-ring at the center of your back.
12. CONSULT FALL PROTECTION SUPPLIER FOR INSPECTION PROCEDURE. INSPECT FALL PROTECTION ANCHORAGE EQUIPMENT BEFORE EACH USE.
13. WHEN A SECONDARY WIRE ROPE SYSTEM IS USED, a horizontal lifeline secured to two or more structural members of the scaffold may be used in lieu of vertical lifelines.

E. DURING USE:

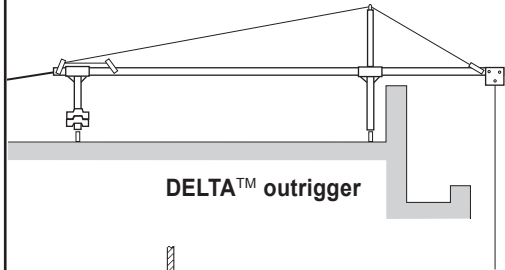
1. USE ALL EQUIPMENT AND ALL DEVICES in accordance with the manufacturer's instructions.
2. DO NOT OVERLOAD, MODIFY, OR SUBSTITUTE EQUIPMENT.
3. BEFORE COMMENCING WORK OPERATIONS preload wire rope and equipment with the maximum working load, then retighten wire rope rigging clamps and check rigging to manufacturer's recommendations.
4. INSPECT ALL RIGGING EQUIPMENT AND SUSPENDED POWERED SCAFFOLDS SYSTEMS DAILY.
5. INSPECT WIRE ROPE DURING EACH ASCENT OR DESCENT FOR DAMAGE.
6. USE CARE TO PREVENT DAMAGE TO EQUIPMENT by corrosive or other damaging substances.
7. CLEAN AND SERVICE EQUIPMENT REGULARLY.
8. ALWAYS MAINTAIN AT LEAST FOUR (4) WRAPS OF WIRE ROPE ON DRUM TYPE HOISTS.
9. DO NOT JOIN PLATFORMS unless the installation was designed for that purpose.
10. ONLY MOVE SUSPENDED SCAFFOLDS HORIZONTAL-LY WHEN NOT OCCUPIED.
11. WHEN RIGGING FOR ANOTHER DROP assure sufficient wire rope is available before moving the suspended scaffold system horizontally.
12. WHEN WELDING FROM SUSPENDED POWERED SCAFFOLDS:
 - a. Assure platform is grounded to structure.
 - b. Insulate wire rope above and below the platform.
 - c. Insulate wire rope at suspension point and assure wire rope does not contact structure along its entire length.
 - d. Prevent the bitter end from touching the ground.

These safety guidelines set forth some common sense procedures for safely erecting, dismantling and using suspended powered scaffolding equipment. However, equipment and scaffolding systems differ, and accordingly, reference must always be made to the instructions and procedures of the supplier and/or manufacturer of the equipment.

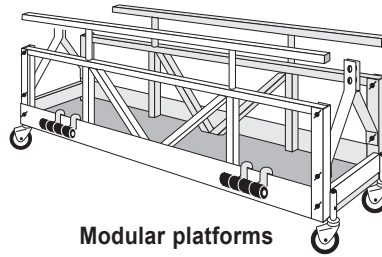
Since field conditions vary, and are beyond the control of the Scaffolding, Shoring and Forming Institute and Scaffold Industry Association, safe and proper use of scaffolding is the sole responsibility of the user.



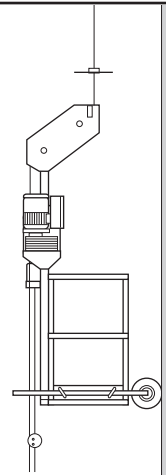
More information about access equipment...



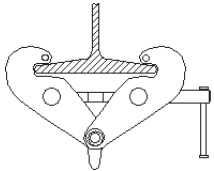
DELTA™ outrigger



Modular platforms



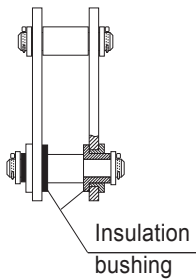
Workcages



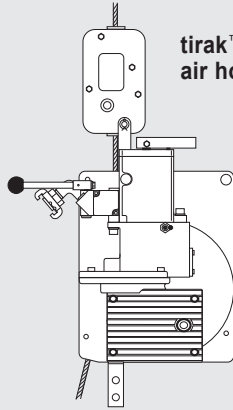
Beam clamps

Electrical Accessories:

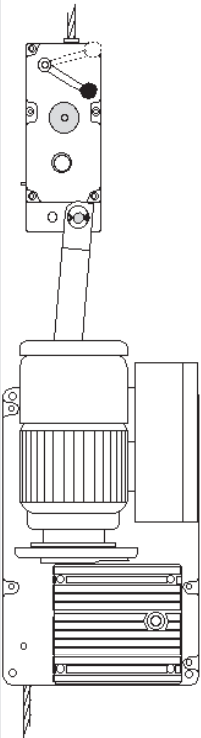
- Power cords
- Power yokes
- Booster transformer
- Insulated thimbles:



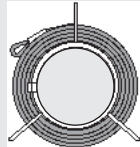
Insulation bushing



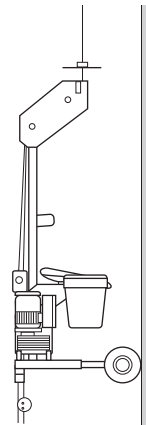
**tirak™
air hoists**



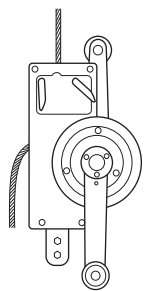
**tirak™
XE 2050 P1
4,400 lbs.
rated capacity**



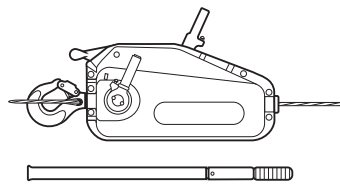
**Wire ropes
in any length**



Bosun's chair



SCAFOR™ manual hoist



GRIPHOIST™ manual hoists



**FALLSTOP®
Personal
fall arrest
systems**

... on request!



Tractel Inc.
Griphoist® Division
 51 Morgan Dr.
 NORWOOD, MA. 02026
 Tel.: (800) 421-0246
 Fax: (781) 828-3642



Tractel Inc.
Griphoist® Division
 315 Cloverleaf Dr., Unit E
 BALDWIN PARK, CA. 91706
 Tel.: (800) 675-6727
 Fax: (626) 937-6730